

VACUUM BOOSTERS

EVEREST

ENHANCING PROCESS EFFICIENCY

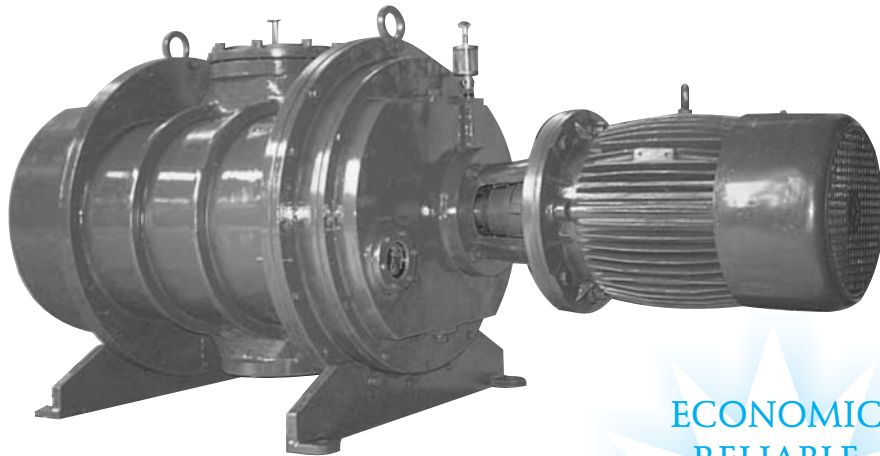

by IMPROVING VACUUM

ECONOMIC
RELIABLE
DURABLE
with the
NEWLY DEVELOPED
EVEREST PROFILE



SALIENT FEATURES	2
COARSE VACUUM APPLICATION	4
HIGH VACUUM APPLICATION	15
GLOSSARY	24
APPENDIX	26

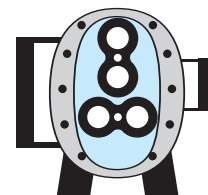

WE JUST DON'T
OFFER BOOSTERS.
WE OFFER
SOLUTIONS!

PRODUCT RANGE

Air Blowers~Water Cooled Blowers~Gas Blowers~Vacuum Booster Pumps~Acoustic Hoods & Enclosures~Dry Vane Pumps

EVEREST Transmission



Mechanical Vacuum Boosters, manufactured by EVEREST, are being extensively used in chemical process industry to boost the performance of the vacuum pumps, in low-pressure range, where conventional vacuum pumps have poor volumetric efficiency.

Everest Vacuum Boosters are capable of moving large quantity of gas at low

Mechanical Vacuum Booster- Model EVB15 with Mechanical Bypass Arrangement

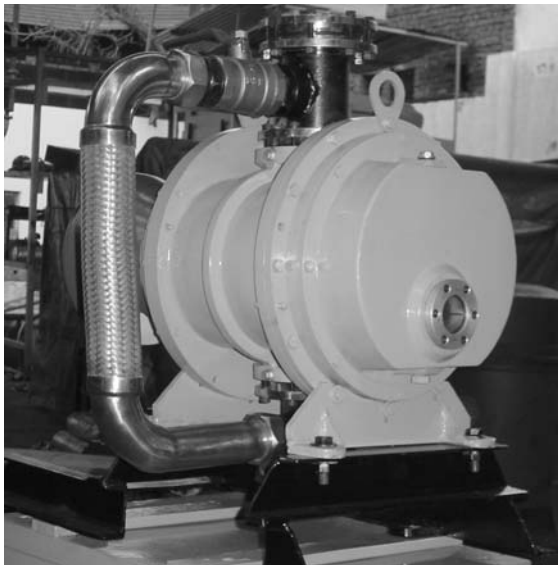

Notes

pressures, with far smaller power consumption than for any other equipment now available. The internals of a Booster are totally free of any sealant fluid, and therefore the pumping is dry. Also because of the vapor compression action by the booster, the pressure at the inlet of the Backing pump is relatively high, resulting in higher volumetric pumping efficiency & low back streaming of sealing fluid. They act as dynamic one way valve. **Everest Twin Lobe Mechanical Vacuum Boosters** are used in series with a variety of backing pumps to achieve higher speeds and lower ultimate pressures. Since the rotors in a Booster rotate within the casing with finite clearances, no lubrication of the internals is required and the pumping is totally oil free.

Everest Mechanical Vacuum booster pumps offer very desirable characteristics, which make them the most cost effective and power efficient option.

THE MAJOR ADVANTAGES

- Can be integrated with any installed vacuum system such as Steam Ejectors, Water Ring Pumps, Oil Sealed Pumps, Water Ejectors, etc.
- The vacuum booster is a Dry Pump, as it does not use any pumping fluid. It pumps vapor or gases with equal ease. Small amounts of condensed fluid can also be pumped.
- Vacuum boosters are power efficient. Very often a combination of Vacuum Booster and suitable backup pump results in reduced power consumption per unit of pumping speed.
- They provide high pumping speeds even at low pressures.
- Boosters increase the working vacuum of the process, in most cases very essential for process performance and efficiency. Vacuum Booster can be used over a wide working pressure range, from 100 Torr down to 0.001 Torr (mm of mercury), with suitable arrangement of backup pumps.
- It has very low pump friction losses, hence requires relatively low power for high volumetric speeds. Typically, their speeds, at low vacuums are 20-30 times higher than corresponding vane pumps / ring pumps of equivalent power.
- Use of electronic control devices such as Variable Frequency Control Drive allows modifying vacuum boosters operating characteristics to conform to the operational requirements of the prime vacuum pumps. Hence they can be easily integrated into all existing pumping setup to boost their performance.
- Vacuum boosters don't have any valves, rings, stuffing box etc., therefore, do not demand regular maintenance.
- Due to vapor compression action by the booster, the pressure at the discharge of



booster is maintained high, resulting in advantages such as low back streaming of prime pump fluid, effective condensation even at higher condenser temperatures and improvement of the backup pump efficiency.

The Table below gives a rough estimate of how the boosters enhance the working vacuums of the processes when installed in combination with various types of vacuum pumps.

VACUUM PUMP	PRESSURE RANGE	PRESSURE RANGE WITH BOOSTER COMBINATION
Single Stage Ejector	150 Torr	15-30 Torr
Water Ejector	100 Torr	10-20 Torr
Water Ring Pump	40-60 Torr	5-10 Torr
Liquid Ring Pump	20-30 Torr	2-5 Torr
Piston Pumps	20-30 Torr	2-5 Torr
Rotary Piston Pumps	0.1 Torr	0.01 Torr
Rotary Vane Pump	0.01-0.001 Torr	0.001-0.0001 Torr

They effectively replace multistage steam jet ejectors, resulting in considerable steam savings and reduced loads on cooling towers. Mechanical Vacuum Boosters are versatile machines and their characteristics depend largely on backing pump. Various types of backing pump can be used, depending upon the system requirement and ultimate vacuum needs. However, the final vacuum is governed by the suitable selection of the backing pump and booster combination. The table below gives a broad range of vacuum achieved with various backing pumps combinations.

Integrated pumping systems that stage two or more pumps in series have become increasingly popular in recent years. Integrated Mechanical Systems are built around the Rotary-Booster. The Booster discharges to a Backing pump which discharges to atmosphere. Using Boosters in this manner extends the range of application of liquid ring pump, water ejectors, rotary piston and rotary vane pumps.

Multi-staging of boosters is also widely used to achieve high pumping speeds at pressures as low as 0.001 Torr.

Everest Twin Lobe Boosters are used mainly in two modes: -

- 1. Compression Mode**
- 2. Transport Mode**

Compression Mode In compression pumping, the general application, a booster is placed in series with a backing vacuum pump whose rated capacity is much lower than the booster capacity. The ratio of

Booster capacity to Backing Pump capacity is termed as STAGING RATIO and the ratio of Booster outlet pressure to inlet pressure is COMPRESSION RATIO. In compression mode the staging ratio ranges between 2-10 while the compression ratios

achieved range between 6-40, depending upon combination selection and process. Initially, pumping is initiated at atmospheric pressures by Backing and after achieving the recommended cut in pressure the booster is switched on. A bypass line around the booster may be provided for the initial pump down period. Boosters with hydrokinematic drive/Variable Frequency control are also available which allow simultaneous start-up of the Booster & the backing pump. The initial pumping by Backing pump is necessary since pumping gas at high pressures with the booster generates considerable heat and the power input is also considerably high. For this reason the booster is generally switched on at cut-in pressures between 20 -100 Torr. Everest Boosters combine high pumping capacity with relatively low power consumption. In chemical process, working in the coarse Vacuum range (10 -100Torr) Staging Ratio of 3-5 are generally selected and compression ratio of the order 5-10 can be expected. For medium vacuum range (<10Torr) higher Staging ratio and compression ratio may be selected.

Notes



COARSE VACUUM APPLICATIONS

Typically in range 1- 100 Torr

Vacuum Drying Application

Tray Dryer

Rotary Vacuum Dryers

Flash Drying

Vacuum Distillation Processes

Solvent Recovery

Vacuum Filtration

Vanaspathi Oil De-odourisation.

Replacement of Steam Ejectors

**Enhancing the performance of
Water Ring Pumps /Water ejectors**

Vacuum Flash Cooling / Evaporative Cooling

Vacuum Crystallization



VACUUM PUMP SELECTION

It is important to understand the terms capacity and throughput and Ultimate / Blank-off vacuum of a vacuum pump as they are the major guiding parameters in selection of the vacuum pumping system. Too small a pumping system would result in inefficient or no process whereas too large a pumping system would result in high capital and operating cost.

For most of the chemical processes vacuum-pumping system is designed to take care of process load and maintain the process to the desired levels of pressures. Process Loads consist of:

- Plant air leakage load
- Process non-condensable such as dissolved gases.
- Process condensable load - vapors which escape the condenser

The sum of the individual loads must be effectively pumped out to maintain the process vacuum. All the above loads are Mass Flow rates (Kg/hr) and the pumping system must be able to pump them out. Most of the vacuum pumps are rated for Volumetric Displacement FAD (m³/hr) and therefore their displacements must match the load at the desired pressure regime.

For example a load of 10Kg of Air at 100 Torr (660mmHg) vacuum, 20°C needs a pump of pumping capacity 63 m³/hr and for the same load at 10 Torr the Pumping speed required would be 630 m³/hr and at 1 Torr would need a pumping speed of 6300 m³/hr.

It is, therefore, important to establish the total load on basis of which the pumping system should be selected. Pumps generally have their optimum pressure range where their capacities are maximum and must be operated in that range.

The Blank Off Vacuum is generally a measure of it's ultimate, where the Capacity is ZERO. It is for this reason series of pumps are used to achieve effective pumping at the designed pressures.

For example a water ring pump with blank-off 50Torr (710mmHg) should be used for processes requiring vacuum in the range around 70-100Torr (690-660mmHg), and for pressures below it, combination of pumps should be used for energy efficiency.

The most important parameter effecting the vacuum pump selection is the suction pressure that must be reached or maintained and throughput the pump must handle. Pumping characteristics for the pump selected are of prime importance as most of the pumps have a working pressure range where they are most efficient and below which their performance drops considerably. The process working pressure and load are the major factors governing the pump selection. Generally there is confusion between the working pressures and displacement.

Invariably the process demands higher working vacuums and the process engineer's end up selecting higher capacity pumps adding to considerable capital & working costs with little or no gain in vacuum. For example if a process demands system pressures to be maintained at 50 Torr (710mmHg) with non condensable load of 10 Kg/hr at 30°C , ideal pump should have a capacity of 130m³/hr at 50 Torr. Use of water ring pump which has it's ultimate at 710mmHg would be a wrong choice. A Booster and Water ring combination would be the most energy efficient choice.

In case the process loads are known, pump selection can be easily made by expression,

$$S_{avg} = \frac{62.511 \times T}{P} \{ \frac{Q1}{M1} + \frac{Q2}{M2} + \dots \frac{Qn}{Mn} \}$$

Where

- Savg Pump speed m³/hr
- T Gas/Vapor abs. Temp, in K
- P Process absolute Pressure in Torr
- Q1, Q2, Qn Gas / Vapor flow rate, in Kg/hr.
- M1, M2, Mn Molar mass, in Kg/mol. of gas /vapor.

Notes

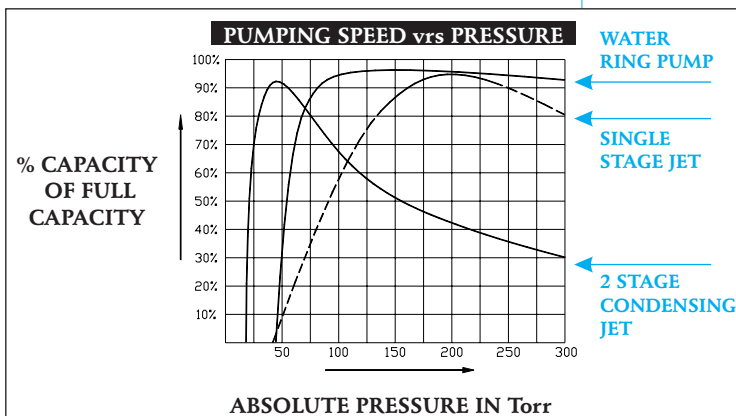

For example, a pump is to be selected to handle 10Kg/hr of air load and 5 kg/hr of water vapor load at 50°C and the process vacuum is to be maintained at 20 Torr. The pump capacity comes to



628 m³/hr i.e. pump selected must have pumping capacity of 628 m³/hr at inlet pressure of 20 Torr.

For an installed system air leakage load can be estimated by "Drop Test" method or the Pressure rise test. Air leaks into the system at a constant rate as long as the pressures in the system are below 400 Torr because of critical flow conditions.

The system is evacuated to pressures between 10-100 Torr and isolated. The pressure is allowed to rise up to about 250-300 Torr and the time lapsed is noted.

The Leak Rate "Q_L" is calculated as,

$$Q_L = \frac{P \times V_s}{t}$$

Where
 Q_L leak rate in Torr Ltrs/sec
 P pressure rise in Torr
 V_s system volume in Litres
 t is elapsed time in seconds

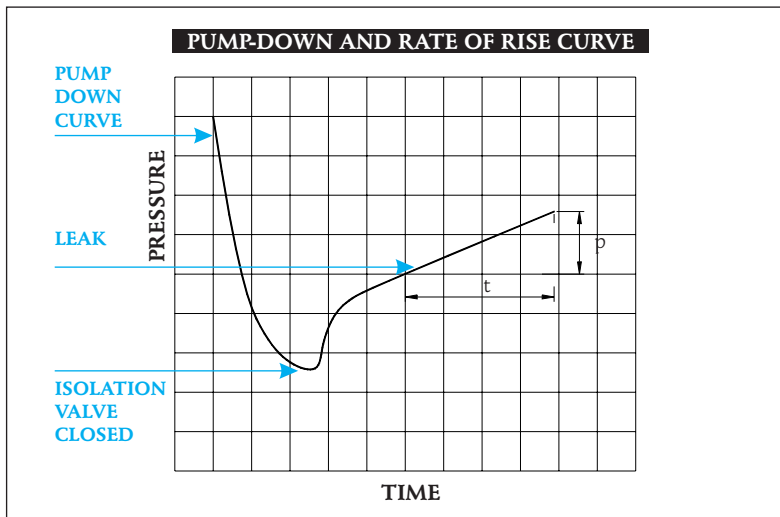

For Air, 20°C, Molecular Wt. 28.9,

$$S_{avg} = \frac{3.6 \times Q_L}{P}$$

Where
 S Average pump speed in m³/hr
 Q_L Leak rate Torr lt/sec
 P System Pressure in Torr

Notes

For example, for a system of volume 10m³ Drop test is done. The system is evacuated to 60 Torr (700 mmHg) and isolated. After 10 minutes the pressure rises to 100 Torr (660mmHg).

Find the Leak rate & the capacity of pump required to pump it out maintaining system pressure to 50 Torr.

$$Q_L = \frac{(100-60) \times (10 \times 1000)}{(10 \times 60)}$$

$$= 666.6 \text{ Torr lt/secleak rate}$$

$$S_{avg} = \frac{3.6 \times 666.6}{50}$$

$$= 48 \text{ m}^3/\text{hr} \dots \text{Pump capacity at 50 Torr.}$$

Pipe Sizing

The piping that connects the vacuum vessel to the vacuum pumping system plays a vital role in the overall performance of the system. Sizing of the pipe requires relatively complex calculations based on various factors like Flow conditions Turbulent, Steady state, Molecular, friction coefficient, Reynolds's No etc. Too small a pipe would have low conductance (High Resistance) restricting the flow rates due to higher pressure drops across it and too large a piping would increase the capital cost.

As a thumb rule for pressures in the range of 10-100 Torr pipeline "D" may be selected as

$$D = 2.4 (Q)^{0.5}$$

Where
 D diameter of pipe in mm
 Q Pumping speed in M³/hr

For a flow rate of 900 m³/hr the suitable pipe calculated is 72 mm, as per above and 80 NB line, the nearest standard size should be selected.

VACUUM PUMP CHOICE

In order to ensure satisfactory operation of any Vacuum process it is essential that suitable vacuum pump be used. There is generally no single pump that meets all the requirements of the process. Combination of pumps are increasingly being used to optimize the process performance. Process condensable & non-condensable loads, air leakage loads, out-gassing loads and the working process pressures are the important parameters that influence the pump selection. Various empirical load estimation charts, HEI (Heat exchange Institute) tables and leak tests must be referred for the proper selection of the Vacuum system. Some of the widely used pumps



for vacuum process are described below along with their limitations.

Ring Type Pumps
(e.g. Water Ring Pump, Liquid Ring Pump)

These pumps use water or low vapor pressure fluid as the pumping medium. For this reason water ring type pumps, the ultimate vacuum achieved gets limited to the vapor pressure of the pump fluid at the working temperature. Owing to the above, Water Ring Pump would stall at around 60 Torr abs. (700 mm Hg) and their working range should be between 60 - 150 Torr (700-610 mmHg). They have further disadvantage of being highly energy inefficient, because most of the power is lost in friction losses of moving the pump fluid inside the pump. This restricts the water ring pump to relatively modest volumetric pumping capacities. Another disadvantage of ring pumps is that the working fluid often has to be treated before it can be discharged or reused as it contains the carry over of condensed product.

Steam Ejectors
Single & Multistage

Steam ejectors have relatively high volumetric speeds. However, they require the maintenance of a complete high pressure steam generation facility conforming to IBAR regulations and inspection. They are generally not available as stand alone installations but are found where high pressure process steam is readily available.

Multistage steam ejectors demand inter stage condensing putting considerable load on the cooling towers. Apart from the direct steam generation cost, large energy and maintenance cost of secondary equipment such as circulation pumps, cooling tower, softening plant, DM plant and boiler maintenance add to recurring expense.

Rotary Vane and Piston Pumps

These type of pumps have high power to capacity ratios and are therefore, not available in large volumetric capacities. They are effective for pumping non-condensable loads but have limitations of not being able to pump large & regular quantities of water vapor (condensable loads) released in low-pressure vacuum processes. Various precautions have to be taken

if they are used for food grade applications to avoid contamination of process material by the pump oil or back streaming of oil vapors.

Everest Mechanical Vacuum Booster

Everest Vacuum Booster is a Dry pump that meets most of the ideal pump requirements. They work on positive displacement principle. As its name suggests, they are used to boost the performance of water ring / water ejectors/ oil ring/ rotating vane/ piston and in some cases steam ejector pumps. It is used in combination with any one of the conventional pumps, to overcome their limitations. Vacuum Booster pump offer very desirable characteristics, making them the most cost effective & power efficient alternative.

$$S = \frac{2.163 \times T \times M_i}{P}$$

- Where
 S Pumping speed m³/hr
 T temperature in K
 M_i air load in kg/hr
 P system pressure in Torr

Notes

As evident from above, at low pressures, higher pumping speeds are required to maintain the through-put (mass flow rate), since the specific volume increases with the increase in vacuum. Vacuum boosters enhance the pumping speeds by about 3-10 times by virtue of which one can expect higher process vacuum and throughputs.

BOOSTER - WATER RING PUMP COMBINATION

Water Ring Pumps are used throughout the process industry. These pumps provide legitimate alternative to steam jet ejectors in



applications requiring rugged pump that can tolerate entrained liquids, vapors and fine solids. These Pumps operate in a liquid environment, generally water and are capable of handling vapors along with non-condensable loads.



They are extensively used in industrial processes such as filtration, drying, solvent recovery, distillation etc. Unfortunately they suffer from two major limitations that restrict the process performance. They being: -

- The final vacuum achievable, as it is largely dependent on the vapor pressure of the pump fluid corresponding to the working temperatures. For example, for water sealed pump, the lowest practical operating pressure for two-stage design would be in the range of 40 60 Torr (720-700mm Hg) for exit water temperature at 30-32 °C.
- Their energy consumption per unit of gas pumped is higher since most of it is lost in handling pump fluid. Vacuum boosters overcome these limitations of liquid ring pump. A properly matched combination can result in:
 - Higher working vacuums any where the range of 50 Torr 1 Torr (710-760mmHg).
 - Very high pumping speeds generally to the order of 4-8 times higher than the backing pump.
 - Vapor/gas compression at the inlet of the water ring pump allowing use of higher water temperature in the pump.
 - Relatively very low energy consumption per unit of pumping speed.

Notes

WRP loosing on one time pump cost and recurring energy charges. The power consumption, however, is constant throughout the range that makes LRP relatively less energy efficient in comparison combination.

Curve2 gives a typical combination speed curve. As the WRP vacuum drops to the range of 60-100 Torr (660-700mm Hg), the Mechanical Booster boosts the effective speed manifold. As can be seen from the curve the booster exhibits relatively flat pumping speed curve in the region 10-1 Torr (750-760mm Hg), high pumping speeds and better process vacuum is achieved, overcoming the limitations of water ring pump, in this range. The power consumption of the Mechanical Vacuum Booster is relatively low in this range as compared to any other conventional vacuum pump. Therefore, with little extra energy, the overall pumping speed and ultimate vacuums can be greatly enhanced. Installation of MVB undoubtly results in high pumping speeds and better vacuums. However, to get the best results in process, its location is important. It can be effectively located between the condenser (**Post-condenser installation**) and the WRP or between the evaporator and the condenser followed by WRP (**Pre-condenser installation**). To enable to determine most effective location process parameters play an important role.

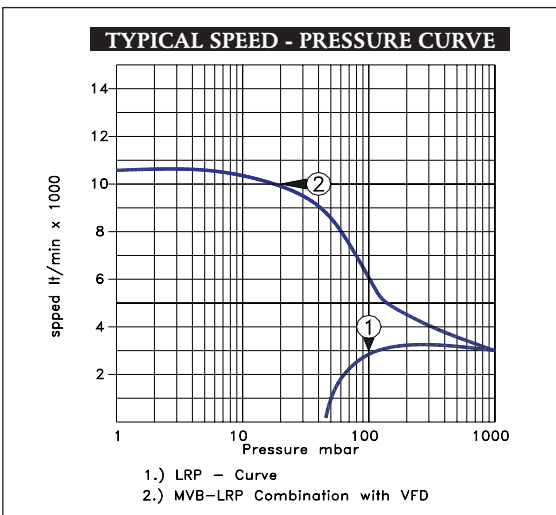

Post Condenser Installations

Processes such as distillation of high boilers (kettle temp. are generally above 125°C) or processes using chilled water condenser or processes having direct discharge of vapors to WRP are some cases where post-condenser installations can give boost to the process, resulting in higher yields, lower process time and better product quality.

Above is a typical water ring pump speed curve. The pumping speed is equal to the rated speed (displacement) during initial pumping and thereafter drops rapidly reaching to zero at its ultimate (690 720 mm Hg). In most of the chemical processes the process vacuum is in the range of 680-700mmHg where the pumping speed of WRP is merely 15-20% of its full rated capacity. This demands installation of much larger

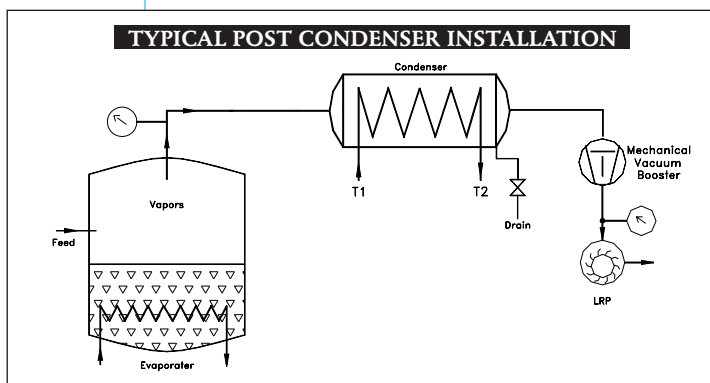



In drying applications where water vapor is exhausted from the dryer and cooling water of 10°-15°C is available in the condenser, post condenser installation would be a good choice. Since the vapor pressure of condensate (Water) is low, low process pressures are possible.

Double stage WRP having fluid temperature in the range of 30-35°C would not be able to deliver working vacuum below 50-60 Torr (710-700 mm Hg). However on installation of Mechanical Booster between the condenser and the WRP would very conveniently pull down vacuum to the range of 15-20 Torr (745-740 mm Hg). Still better vacuums can be possible if the condenser & condensate temperatures are lowered further.

performance is not effected by vapors as it can pump both condensable & non-condensable with equal ease.

Pre Condenser Installations

For applications where condensate is a low boiler, low temperature drying or process where condenser temperature cannot be maintained low, pre-condenser booster installation would give very encouraging results. In Pre Condenser installation the Booster is installed between the evaporator and the condenser and handles the entire process vapors.

Principally condensation is just reverse of evaporation and therefore process parameters

favorable for evaporation are generally not favorable for condensation and accordingly process parameters favorable for evaporation are not favorable for condensation. In most of the processes vacuum system is installed in the fag end resulting in the entire process being under similar levels of vacuum. Thus a compromise is made regarding the system vacuum to get optimum results that generally are not the best, leading to high process time and compromise on product purity. Installation of Booster between the evaporator and

Notes

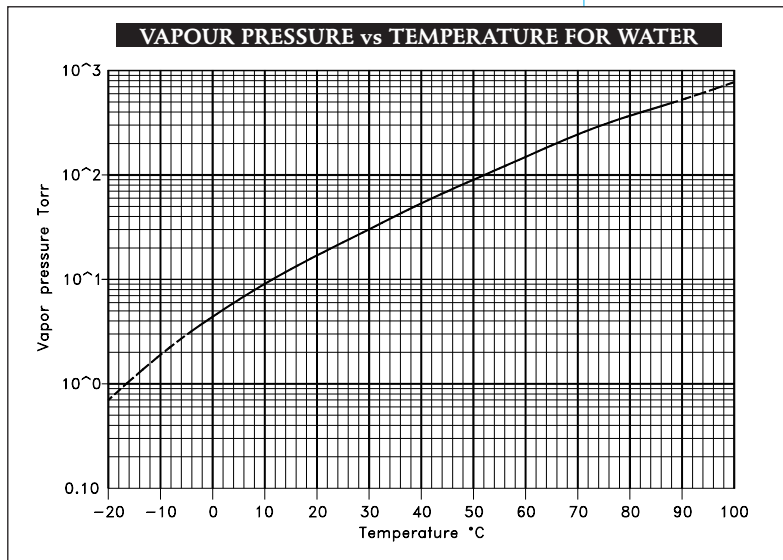

In some applications of drying/solvent recovery, it is more important to exhaust solvent to very low levels, typically less than 1%. At those levels recovery and collection of solvent may not be very critical but product purity is of vital importance. In such applications post condenser booster installations prove very effective. Initially when the solvent percentages are high Booster can be by-passed and most of the solvent recovered in the condenser.

condenser overcomes the above limitations by creating high vacuum conditions at the evaporator and relatively high-pressure conditions at the condenser, both of which tend to create ideal conditions in the evaporator and condenser for maximum efficiency. This would accelerate evaporation and at the same time allow full condensation in the condenser.

As the concentration of the mixture improves, leaving low percentage of solvent, need for finer vacuums and higher temperatures are felt. At this stage the condensate can be drained out from the condenser and Booster started, give high pumping speeds and finer vacuum. This would greatly enhance evaporation of solvent, giving high product purity. Booster

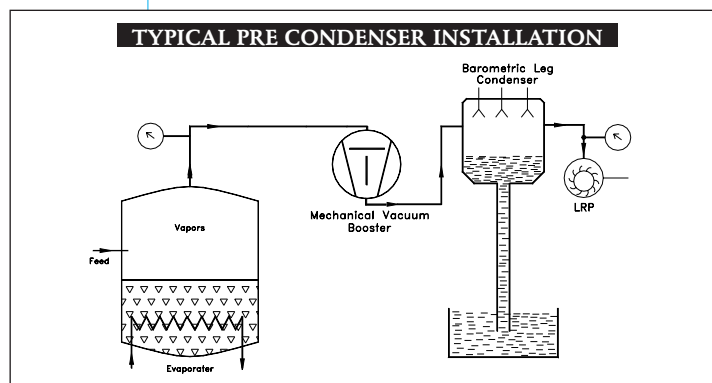



Due to lower vacuums in the evaporator, lower evaporator temperature and better product purity can easily be achieved in a much shorter time. Similarly due to higher pressure at the condenser, higher rate of condensation can be expected. Booster can create favorable conditions both for evaporator and condenser, which otherwise may not be possible, resulting in better yield, better product quality and better recovery of condensate.

Boosters are, therefore, an ideal choice for all major vacuum processes and their installation would definitely result in shorter process times and better product quality. Since various factors influence a process, proper selection and installation of Booster can yield good results in most of the cases.



DRY MECHANICAL BOOSTERS REPLACE STEAM EJECTOR

Steam ejectors find wide use in vacuum pumping applications so called dirty application such as in Vapor extraction, Chemical processing, Evaporative Cooling, Vacuum distillation, Vegetable oil de-odourization, Vacuum Refrigeration, Drying etc. In spite of the fact that steam ejectors have poor overall efficiency and relatively high-energy consumption, they are popular in vacuum applications because of their simplicity and ease of operation. It's high time now when the industry should realize the disadvantages associated with it and switch over to efficient alternatives Dry Mechanical Vacuum Booster being one of them. Mechanical Vacuum Booster offers an efficient replacement to steam ejector, for most of the applications, as they overcome major

drawbacks associated with steam ejectors. The major advantages of Mechanical Booster being:

- Mechanical Vacuum Boosters are more energy efficient.
- Minimum of auxiliary equipment is needed; unlike for steam ejectors, which need large condensers, cooling towers, re-circulation pumps etc.
- Mechanical Vacuum Boosters are dry pumping system and don't give rise to water and atmospheric pollution.
- Startup time for mechanical booster is very low making them ideal for Batch process operation where immediate startup and shut down is essential for energy conservation.

Steam Ejectors

Steam ejectors comprise of converging diverging nozzle through which high-pressure steam (motive fluid) is forced. The ejector nozzle converts the high-pressure head of the motive fluid into high velocity stream as it emerges from the nozzle into the suction chamber. Due to increase in velocity head, there is a drop in pressure head causing partial vacuum in the suction chamber. Pumping action occurs as the fluid / vapors present in suction chamber are entrained by the motive fluid and are carried into the diffuser, by viscous drag process.

In the diffuser section of the nozzle, the velocity of the mixture is recovered to pressure head greater than suction pressure but much lower than the motive pressure. This pressure (diffuser pressure) must be equal or higher than the backing pressure for stable operation.

In order to get low vacuum, multiple stages are used which are broadly classified in the, table below:

NUMBER OF STAGES	OPERATING SUCTION PRESSURE	APPROXIMATE STEAM CONSUMPTION PER KG OF SUCTION LOAD
1	200 - 100 Torr	4 - 8 Kg
2	60 - 40 Torr	15 - 20 Kg
3	20 - 5 Torr	18 - 25 Kg
4	3 - 0.5 Torr	20 - 100 Kg

The capacity of steam ejector is directly proportional to the weight of the motive fluid. Generally, the ratio of motive fluid to the gas

Notes



pumped is high, especially under low pressures and results in excessive demand of steam in multi-stage systems. The overall performance of steam ejector is sensitive to changes in operative parameters such as motive steam pressure and discharge pressure. A slight variation in operating parameters weighs heavily on the system capacity.

Multi stage steam ejectors require inter-stage condensing as each stage adds to the pumping load for the succeeding stage and for reason of economy, condensation becomes important. The heat gained during condensation i.e. latent heat of vaporization, adds to the need for additional equipment such as re-circulation pumps, cooling towers etc. so that the same can be dissipated. In a steam ejector, steam comes in direct contact with gas/vapor pumped and many a times, this mixture of pumped vapor and water needs elaborate treatment before it can be discharged/re-used.

Steam ejectors, especially multistage not only require steam generation facilities but also raise demand for auxiliary equipment such as D.M. plant for boiler feed water, condensing units, re-circulation pumps, cooling towers, effluent treatment plant etc. thereby increasing total energy consumption and maintenance costs. Steam ejectors are therefore, no longer popular as they were once, because of dramatic increase in cost of steam generation, auxiliary power and effluent treatment problems.

It is for this reason many steam ejector installations have been replaced by mechanical Vacuum Pumps which use far little energy for the same service and require no additional auxiliary power, cooling tower nor give rise to effluent.

- Purification by removal of unwanted volatile elements.
- Solvent recovery.
- To increase shelf life and to facilitate further processing and permit proper utilization of the final product.
- To reduce shipping costs by reducing weight of the product.
- To reduce the rate of biological decay.
- To enhance the value of by products of a process.

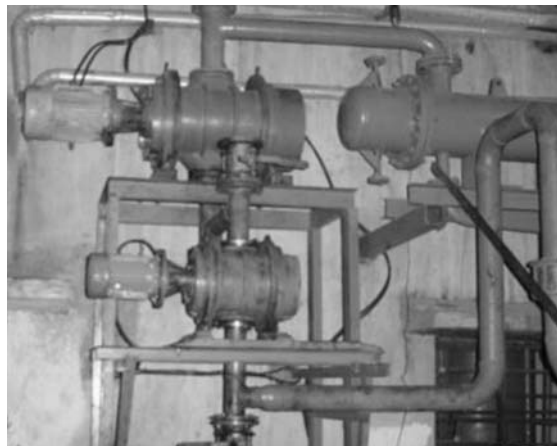

Notes

The diagram below shows typical low temperature drying installation. Conventionally, Water Ring Vacuum pump/ Water Ejector/Steam ejector or Piston Pumps are used to create vacuum. They have limitations to the Ultimate Vacuums achieved, pumping speeds, pump fluid contamination and consume relatively high energy.

VACUUM BOOSTERS FOR DRYING/SOLVENT RECOVERY APPLICATIONS

Drying is a process of removal of a liquid from a solid mixture by thermal means. Various drying process & techniques are extensively used in the various Process industries, Pharmaceutical industry, Food processing industry, Dye & Chemical industry, Perfumes & Permitted Food additive industry etc primarily to achieve one or more of the following:

- Product concentration at low temperatures.

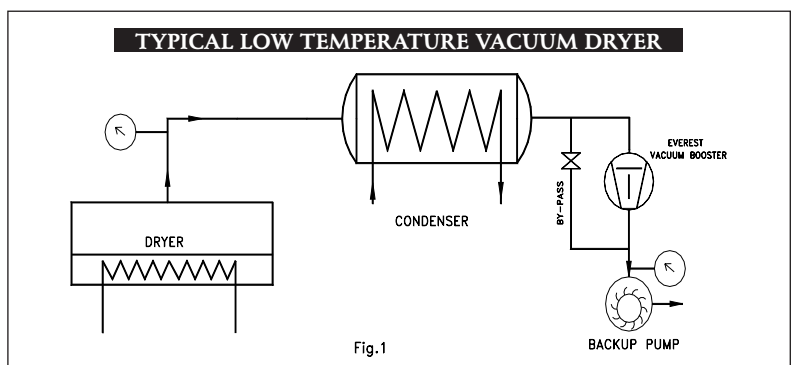

A vacuum Booster, when used in conjunction with any of the above, over comes all the associated limitations and increases the overall process efficiency by increasing the vacuum and pumping speeds with relatively very little extra energy.



In most chemical processes solute is to be concentrated to high degrees of purity and the relatively volatile solvent is to be recovered for reuse. Initially in the solution, when the solute concentrations are low, evaporation of solvent is relatively fast but as the solute concentration increases, the process becomes slow and demands higher temperatures or lower pressures to continue. In most of the processes the increase in temperature is restricted and therefore the pressures must be reduced to continue the process.

Let us consider a mixture of two completely miscible volatile liquids A & B having mole fraction x_A & x_B respectively. Let their partial Vapor pressures at any certain temperature T, be P_A & P_B , and p_A^o & p_B^o be their vapor pressures in pure state, corresponding to temperature T.

According to Raoult's law: "In a solution, vapor pressure of a component (at given temp.) is equal to the whole fraction of that component in the solution multiplied by the vapor pressure of that component in the pure state". Therefore,

$$P_A = x_A p_A^o \text{ \& \ } P_B = x_B p_B^o$$

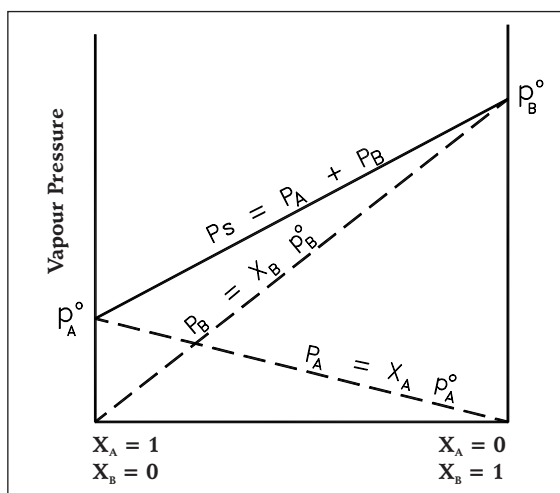

So P_s , Total pressure of solution (according to Dalton's law of partial pressure) is equal to the sum of partial pressures.

$$\begin{aligned} P_s &= P_A + P_B \\ &= x_A p_A^o + x_B p_B^o \\ &= (1 - x_B) p_A^o + x_B p_B^o \text{ (since } x_A = 1 - x_B) \\ &= (p_B^o - p_A^o) x_B + p_A^o \end{aligned}$$

When $x_A = 1$ i.e liquid is pure A, then the total pressure, $P_s = p_A^o$

When $x_B = 1$ i.e liquid is pure B, then the total pressure, $P_s = p_B^o$

In case of solvent recovery / product concentration, product A can be taken as non-volatile solute in volatile solvent B. That is, the vapor pressure p_A^o , at any given temperature is relatively very low in comparison to p_B^o or in other words the Boiling point of A is relatively higher than product B.

The equation (1) can be re written as,

$$P_s = p_B^o \cdot x_B$$

Ignoring p_A^o , being relatively small

Initially the vapor pressure, P_s of the solution, when molar concentration of B is relatively high, is close to p_B (vapor pressure of pure B at the specific temperature T) As the solvent evaporates, molar concentration of B drops resulting in drop of the vapor pressure of the mixture.

This indicates that as the process of concentration proceeds, the amount of solvent present in the solution reduces and for maintaining the same evaporation rates either the pressure must be reduced or temperature increased. In case any of the above is not done, the rate of evaporation / solvent recovery would fall drastically.

If a solution contains, W_A kg of solute of Mol Wt. M_A , dissolved in W_B kg of solvent of Mol. Wt. M_B , we have,

$$P_B^o - P_s = \frac{W_A M_A}{W_A M_A + W_B M_B}$$

Where

- P_B^o Vap. Pressure of Pure Solvent
- P_s Vap. Pressure of Solution
- W_A Mass of solute
- M_A Molecular Wt. Of Solute
- W_B Mass of solvent
- M_B Molecular Wt. of Solvent

Since $(P_B^o - P_s)$ = lowering of vapor pressure of solution, expression 1 can be expressed as "The relative lowering of vapor pressure of a solution, containing non volatile solute, is equal to the mole fraction of the solute in the solution".



Example

Let us take solution of Solute 'A' (Mol. Wt 45) in solvent Acetone (Mol. Wt. 58) in which the concentration of solute A is 1%. The vapor pressure of Pure Acetone at 25°C is, say, 195mm Hg (abs).

Now Vapor Pressure of Solution P_s at temp 25° would be less than P_s by amount,

$$\frac{1/45}{(1/45 + 99/58)} \times 195 = 2.5 \text{ mm Hg}$$

$$P_s = 195 - 2.5 = 192.5 \text{ mm Hg}$$

Now when the solvent evaporates, say 90gm is evaporated the concentrations then are now 1gm and 9 gm for solute and solvent respectively.

The vapor pressure drop would be

$$\frac{1/45}{(1/45 + 9/58)} \times 195 = 24.4 \text{ mm Hg}$$

The pressures must be dropped by at least 25 mmHg or temperatures raised to new boiling point levels, to enable evaporation to continue.

Further, when say 98gm of solvent has evaporated and the concentration is 1gm of

solute and 1gm of solvent, the drop in vapor pressure would be

$$\frac{1/45}{(1/45 + 1/58)} \times 195 = 109.8 \text{ mm Hg}$$

$$P_s = 195 - 109.8 = 85.2 \text{ mm Hg}$$

This explains why lower and lower vacuums are required in a process where solvent evaporation is done to achieve fine concentrations and purity levels. High bottom product purity and maximum solvent recovery both can be effectively achieved. In cases where the evaporator temperatures are close to the boiling point of solvent, the booster can be initially bypassed, as the condenser would maintain the required differential pressures for vapor flow. However, as the concentration increases BP of the solution increases and the need for reduced pressures become essential for process to continue. At this stage the booster can be operated to create lower pressure in the evaporator and relatively higher pressure in the condenser creating higher differential pressures, which would speed up the entire process. Considerable reduction in process time, higher product purity and better solvent recovery can easily be achieved.

Notes

Auto method Installation of mechanical By-pass arrangement across the booster or hydro kinematic drive or Variable Frequency Drive (VFD). In this arrangement, the booster and backing pump can be started simultaneously from atmosphere.

ELECTRONIC VARIABLE SPEED CONTROL DRIVE (VFD) FOR EVEREST BOOSTERS

For process industry, VFD is strongly recommended for Mechanical Boosters as they provide total operational safety and uninterrupted operations. It makes the process so flexible that various operating conditions, as required by the process can easily be achieved by just press of button or can be easily programmed for total automation. These drives enhance the overall performance of the Boosters and offer various advantages for the trouble free operation of Boosters.



Booster Operation

Power Constraint and temperature rise restricts the total differential pressures across the booster. This demands to ensure the total differential pressure across the Booster must not exceed the rated limits. This can be ensured by any of the following means:

Manual methods Initially the backing pump is switched on until the required cut in pressure is achieved and thereafter the booster is switched on.



MAJOR ADVANTAGES

- Booster can be started directly from atmosphere
- No need for separate pressure switch, by pass line or offloading valves.
- Considerable saving in power.
- Prevent over-heating of Boosters.
- Protect the Booster against overload and excessive pressure.
- Offers complete protection to electric motor against over voltage, under voltage, over current, over-heating, ground fault.
- Eliminates the needs of separate starter and overload relays for the Motor.
- Automatically adjusts the speed of Booster/Motor to meet the current set parameter.

Notes

The Electronic Variable Frequency Drive is a microprocessor based electronic drive which is specially programmed to meet the demands of the Booster allowing it to operate directly from atmosphere along with suitable fore pump. Principally a vacuum booster should only discharge into a fore pump as it cannot discharge into atmosphere directly due to power constraints. Boosters are primarily meant to enhance the pumping speeds and ultimate vacuums of the fore pump, which may be Rotary Oil sealed type, Water ring type, Steam ejector, Water ejector, Piston Pump etc. Conventionally the fore pumps are initially started and after achieving cut-off vacuum boosters are started. Use of Pressure Switch, Hydro kinematic drive and mechanical by-pass valves are necessary to prevent the overloading of the Booster. However, with the installation of Electronic Variable Frequency Drive all the conventional methods can be bypassed since the drive is programmed to regulate automatically the Booster speed, keeping the load on Motor within permissible limits.

The drive limits the Booster speed to safe speed and as the vacuum is created the Booster speed picks up to the final preset speed, giving most optimum performance over the entire range. This drive can be set to achieve higher motor speeds than the motor rated speeds since increase in frequency beyond 50 Hz., results in higher speed of the Motor without causing any harm to it. Since all the parameters are easily programmable, one can adjust the booster pumping speeds to match the system requirements easily and quickly. The drive limits the current to the Motor and safeguards the motor against over voltage, under voltage, electronic thermal, overheat ground fault... i.e. protects the Motor against all possible faults.

External computer control over all aspects of booster performance is possible via RS485 serial interface built into the drive electronics. This enables the Booster to be integrated into any computer-controlled operating system.





HIGH VACUUM APPLICATIONS

Typically in range 0.001- 1 Torr

Efficient backup for Diffusion Pump Systems

Thin Film Deposition /Coating

Short path/ Molecular Distillation

Solvent Recovery

CFL, Tube Light & General Lighting industry

Object & Roll Metallisers

**Vacuum Heat Treatment and
Degassing / Vacuum Furnaces**

Semi Conductor Processing

Transformer oil De-humidification

Chemical Laser Applications

Freeze Drying

Vacuum Impregnation

De-humidification

De-gassing

Notes



MEDIUM VACUUM APPLICATIONS

In compression pumping, the general application, a booster is placed in series with a rotary pump whose rated speed is much lower than the booster speed. The ratio of Booster speed to Pump speed is termed as STAGING RATIO and the ratio of Booster outlet pressure to inlet pressure is COMPRESSION RATIO.

In compression mode the staging ratio ranges between 2 - 15 while the compression ratios achieved range between 10-40, depending upon combination selection. Initially, pumping is

initiated at atmospheric pressures by Rotary pump/Fore pump and after achieving the recommended cut in pressure the booster is switched on. A bypass line around the booster may be provided for the initial pump down period. Boosters with hydrokinematic drive/Variable Frequency control are also available which allow simultaneous start-up of the booster &

the fore pump. This initial pumping by fore pump is necessary since considerable heat is generated by pumping gas at high pressures with the booster and the power input is also considerably higher. For this reason the booster is generally switched on at cut-in pressures of 20-60 Torr. A suitable vacuum switch can be installed between the booster & the fore pump, set for cut-in pressure, so that the booster is switched on only on achieving the designed cut-in pressures. However, for short duration the booster can withstand excessive differential pressure across it. The Booster-Rotary Pump combination are generally recommended when speed of 3000 LPM or higher are required since the combination is most economical and power saving than any rotary pump of similar capacity.

As evident from the Typical Performance Curve, booster is most effective in the pressure range of 1 -0.001 Torr having high pumping speeds and relatively low power consumption for this range.

A Typical performance curve is drawn for a Booster combination indicating the individual and combination performance with single stage & double stage rotary pump.

In transport mode pumping, the Booster is used in series with the rotary pump with staging ratio 1. Both the pumps are started simultaneously at atmospheric pressures since the critical pressure drop can never exceed. This combination effects higher ultimate pressure without much increase in pumping speed. However, throughput at lower pressures increases resulting in higher ultimate pressure.

Notes

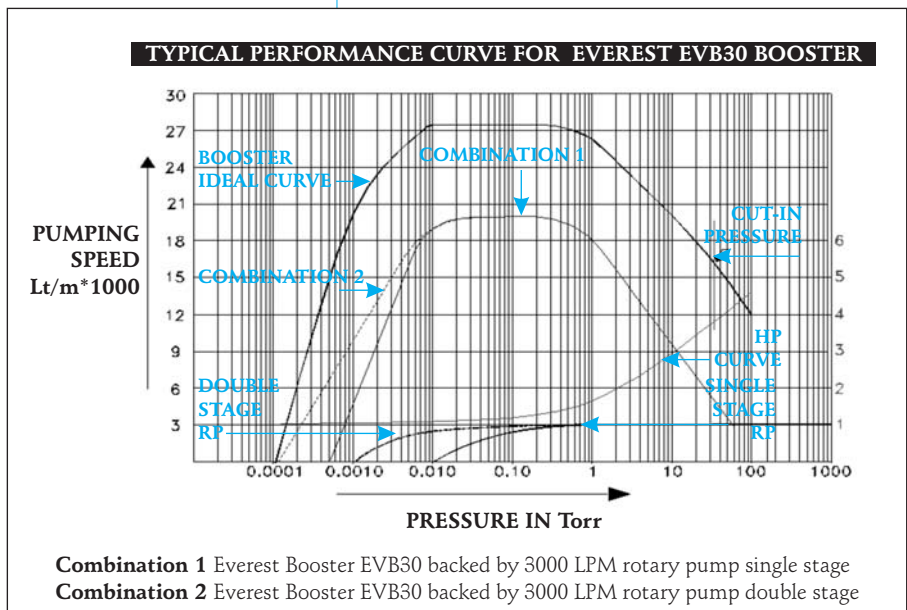

The use and application of Everest Boosters in Industry

Vacuum Roots Blowers are widely used in the industry. Until recently their use in India was restricted because the item was imported and therefore very expensive. However, for the past few years Everest Blowers have been making the item and its usage has increased by leaps and bounds. Today there are hundreds of installations using this product.

So this is a good time to look at various applications and see how Everest Boosters can improve performance and reduce energy costs.



SOME OF THE APPLICATION AREAS FOR EVEREST MECHANICAL VACUUM BOOSTER

BOOSTING THE PERFORMANCE OF DIFFUSION PUMP SYSTEMS

Vacuum metallizing plants are widely used to produce a vast range of metallized plastic/glass/metallic objects, such as reflectors, mirrors, clock and radio cabinets. A typical plant is shown in Figure before. For fast production, a typical cycle time is 6 to 10 minutes, though times in excess of 30 minutes are not unknown. A series combination of a rotary oil-sealed mechanical pump and a Diffusion pump are generally used. The problem is that in the pressure range 10^{-3} Torr to 1 Torr, the speed of both the pumps is very low, hence pump-down times are generally slow. A look at the speed characteristics of typical Oil-Sealed Rotary Pump will show that the pump speed rapidly starts falling at pressures below one Torr. The speed of the diffusion pump starts to fall rapidly at pressures above 0.001 Torr. Hence, in the transition pressure range of 0.0001 to 1 Torr both rotary and diffusion pumps perform well below their optimum levels. The consequence of this is that the overall process cycle is lengthened. This results in high energy and overhead costs. Everest Booster has its peak pumping speeds in the pressure range of 0.001 Torr and 1 Torr. Further because there is little friction in the rotating parts, high pumping speeds are possible at low power consumption. In the transition pressure range Everest Booster can provide five to ten times more pumping speed than the Rotary Pump of the same HP. Thus, to boost the performance of a Diffusion Pumped system, the modern trend is to use a Mechanical Booster between the rotary pump and diffusion pump. Everest Vacuum Booster inserted between the Diffusion and Rotary pump provides a high or boosted pumping speed and thereby enables a fast pump-down process cycle. The productivity improvement can be as high as 100% to 200%.

Advantages of using Everest Booster

- Higher pumping speed by a factor of 5 to 10 times that of the rotary pump.
- Power Saving: The Everest Booster, by virtue of speed enhancement and shorter process cycles, saves power.
- Long service life and very low maintenance because there are no rubbing/mechanical friction between internals.
- Less frequent oil changing.

IMPROVING THE QUALITY OF LAMPS

For quality Bulb, Tube Light or CFL good vacuum is an essential process requirement. Conventional vacuum pumps are unable to offer high pumping speeds in the vacuum range of 10^{-2} - 10^{-3} torr as they approach their ultimate, where pumping speeds drop to almost zero. Mechanical Vacuum Boosters are ideal pumps for such applications as they not only enhance the ultimate vacuum levels but also increase the pumping speeds many fold. These Vacuum Boosters are compact and low energy consuming machines and can easily be integrated into the existing setup. In most of the cases they can be directly mounted on top of the rotary pumps, requiring no additional space, foundations, piping etc. Mechanical Boosters offer high pumping which ensures total evacuation of the bulb prior to its sealing. The requirement of high-speed machine operation where frequent leakages occur due to breakage and wear and tear places heavy demands on pumping systems. The consequence of this is that rotary pumps are frequently replaced due to deterioration in performance.

Everest Booster improves matters by

- Increasing the speed of the Rotary pumps by a factor of 3-5 times.
- Enables less frequent maintenance of the rotary pump, since it can deliver less than peak performance and still provide adequate/superior vacuum to the machine.
- In the production of vacuum lamps using Everest Booster substantially improves the product quality and life.

USE IN VACUUM HEAT TREATMENT AND DEGASSING

Vacuum annealing is necessary for those special steels, which would get embrittled due to incorporation of oxygen if heated in air. Heating under vacuum and subsequent quenching in inert gas is sometimes the only method that is possible for treatment of such steels. Since heating imposes considerable gas loads on the rotary pump, Everest Booster provides the benefit of being able to handle these heavy gas loads at low pressures in an economical way.

A major advantage with Everest Booster is easy and instantaneous startup, unlike diffusion pump or oil booster, which requires substantial heat up time (and consequent waste of energy) to come up to a state of operational readiness.

Notes



USE IN DRYING APPLICATIONS

Everest's Mechanical Vacuum Booster find great use in low temperature drying applications such as pharmaceuticals, food grade products and other thermally sensitive products. Since the specific volume increases many fold with the decrease in pressure the need for a good pumping system is felt which can maintain large pumping speeds at low pressures. Vacuum Boosters offer a ideal solution to meet the above need as they have high pumping speed for relatively low energy consumption. The pumping is totally dry as there is no sealing/motive fluid involved. These boosters can pump both condensable and non condensable loads with equal ease. As the pumping is dry they can be used conveniently for food grade and pharmaceutical applications where dry pumping is an essential requirement. Various industries such as milk drying, mechanized brick drying, katha drying, and thermally sensitive chemicals drying units are already using Vacuum Boosters.

Notes

They also acts as barriers / one way valves due to their high pumping action, minimizing back streaming of Backup pump fluid. Due to effective vapor compression at their discharge they increase the efficiency of traps and secondary condensers, thereby increasing the backup pump life and minimizing backup pump fluid contamination. In certain typical distillation processes the process time can be reduced by almost 50%. Boosters can be easily integrated into any vacuum setup as they do not require any major installation modifications nor require any process utilities. In many cases they effectively replace cumbersome steam ejectors. Mechanical Vacuum Boosters are low maintenance machines and do not have any valve, stuffing boxes, pistons etc. a constant source of nuisance for maintenance engineers.

USE IN SHORT PATH / MOLECULAR DISTILLATION

Everest's Mechanical Vacuum Boosters offer most energy efficient alternative to industries performing short path and high Vacuum Molecular Distillation. Mechanical Boosters are dry vacuum pumps requiring no sealing /motive fluid and for this reason energy consumption is very low in comparison to any other vacuum pump. They can be easily integrated with most of the vacuum systems, to enhance the ultimate vacuum and pumping speeds. Boosters are very versatile and can be used with any backing pump

such as water ejectors, water ring pumps, steam ejectors, oil sealed rotary pumps etc. In many installations they have effectively replaced cumbersome Steam ejectors.

Vacuum Boosters can easily achieve vacuum levels of the order of below 1Torr required ed for such applications. This not only enhances the product quality and purity but also lowers the kettle temperatures yet maintaining high throughputs. Vacuum Boosters have been successfully installed in Menthol distillation industry, Vegetable oil deodorization and other similar processes. In fact for any application where large pumping speeds in the vacuum range below 1 Torr are required, there boosters offer most cost effective and energy efficient alternative

The outstanding advantages of using Everest Vacuum Booster

- Negligible environmental pollution compared to steam ejectors.
- Dry operation. This means that no working fluids are used in the operation of the pump and therefore there are no problems of contaminations of or by the condensate.
- Instantaneous startup and shut down.
- High energy efficiency per unit of pumping capacity.



USE IN GAS-RECIRCULATION AND GAS PRESSURE BOOSTING

In systems that re-circulate gases, such as lasers, heat exchangers and chemical process plants, the use of Everest Booster is essential to overcome the pressure losses of pipeline and sealed chambers. Everest Boosters have the outstanding advantage that they offer dry



operation, which can be totally sealed off from the surrounding atmosphere.

In long pipelines, Everest Boosters can be used to boost the gas pressure. This reduces the requirement of high driving pressures to pump gases through pipes and because Everest Booster is totally sealed and oil free, even inflammable gases such as biogas, L.P.G, C.N.G, etc., can be easily pumped.

USE IN SEMI-CONDUCTOR PROCESSING

Everest Mechanical Vacuum Boosters are used in Semi-conductor processing industry as a part of dry pumping / oil-free pumping systems. Such systems are necessary to handle the high corrosive and often poisonous gases used in semi-conductor production. The main advantage of the Everest Booster is its sealed off operation and long life between maintenance procedures.

USE IN FREEZE DRYING

Modern food processing industries are rapidly switching over to Freeze Drying as it offers longer shelf life and maintains the basic nutrients and aroma. In freeze drying water is frozen and then sublimed. For this process large pumping speeds at low pressure is an essential requirement for the pumping system. Mechanical Vacuum Boosters are found to be the most suitable pumps as they have high pumping speed in the vacuum range of 10^{-1} - 10^{-4} torr and are capable of handling large volumes of vapor. The internals are dry and therefore the machines are safe for food grade applications. They also act as a one way valve due to high pumping speeds preventing back streaming of pumping fluid of the backing pump. Since the internals run dry and there is no internal friction, the power consumption for these boosters per unit of pumping speed is very low in comparison to any other available pump. They are capable of

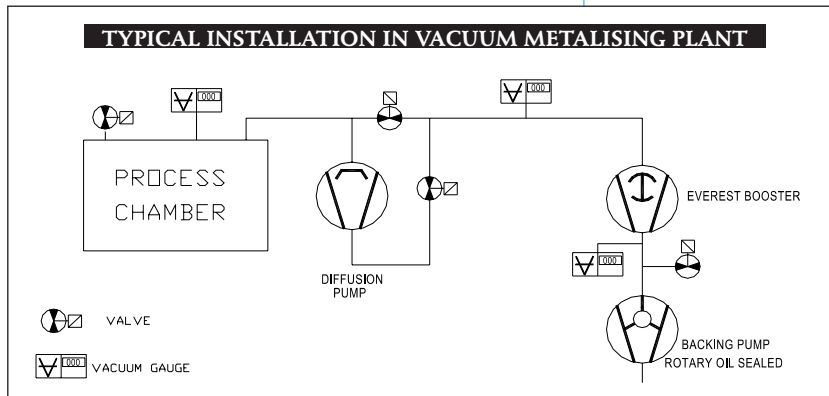

Typical arrangement of Booster installations are shown. The booster can be directly mounted on the suction of the fore pump or mounted on a base frame with connection to fore pump. For applications involving pumping of CONDENSABLE VAPOR like in distillation, a suitable condenser can be installed in between the Booster & Fore pump. In such cases the Fore pump size can be reduced drastically, to match the NON-CONDENSABLE load.

Initially the fore pump is switched on until the required cut in pressure is achieved and thereafter the booster is switched on. In case mechanical By-pass arrangement across the booster or hydrokinematic drive or Variable Frequency drive is used, the booster and fore pump can be started simultaneously from atmosphere.

meet the individual process requirements. They have a wide vacuum operating range typically 10^{-4} Torr to a few mm of Hg. The power consumption is directly proportional to the differential pressure across the inlet and the discharge and therefore when working in the vacuum range of less than 1 mm Hg the power requirement is very low.

USE IN TRANSFORMER OIL DEHUMIDIFICATION

Everest's Mechanical Vacuum Boosters are extensively used in Transformer Oil Purification systems to meet the need of high pumping speeds at low pressures of the order of 10^{-1} - 10^{-3} torr. Generally, most of the rotary oil sealed pumps are unable to maintain pumping speeds at such vacuum levels and demand frequent oil change. Vacuum Boosters when used in such a system overcomes the above limitations making the

Notes



entire process more effective, efficient and faster. Vacuum Boosters offer dry pumping as the internals do not need any lubricant. By virtue of

above they are highly energy efficient machines as most of the power spent is on gas / vapor compression with very little frictional loss, unlike other pumps where considerable amount of power is wasted in friction.

With the use of auxiliary equipment such as mechanical bypass valve, hydro kinetic drive or variable frequency control drive they can be started directly from atmosphere. However, they are most effective and efficient in the vacuum range below 1 torr. Their pumping speed peaks at about 10^{-1} torr. With proper selection one can expect increase in pumping speeds up to 10 times the backup pump speed.

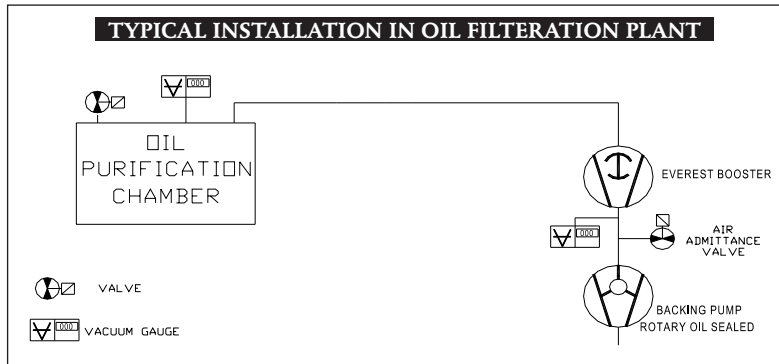

1.) The Rotary Vacuum Pumps RP I, single stage & RP II, Double stage data indicated above is from Rotary Pump manufacturer's catalogue and is only for reference purpose. Actual data may vary from manufacturer to manufacturer. Please confirm with manufacturers catalogue.

2.) Everest Booster is to be switched on only after roughing is done and Cut-in pressures are obtained. Starting prior to the cut-in limits would result in excessive power consumption and booster heating resulting in serious damage. Use of pressure switch is recommended. In case it is desired that the Booster & Rotary pump should start simultaneously use of hydrokinematik drive/Variable Frequency Control drive is recommended.

3.) The Boosters can be used with any other Backing pump like Rotary Piston pumps, Liquid Ring pumps, Water or Steam Ejectors - to increase the overall pumping speed and ultimate vacuums.



EVEREST BOOSTER COMBINATION DETAIL

BACKUP PUMP DETAIL COMBINATION DETAIL

		CAPACITY		H.P.	ULTIMATE		CUT-IN PR. STAGING	
		Lt/min	mBar		Lt/min	mBar	H.P.	Ratio
EVEREST EVB05 400 m³/hr (6700 lpm) 2 HP/1500 rpm	R.PI	500	0.020	1.0	4400	0.0008	25	13.4
	R.PII		0.002	1.0		0.0002		
	R.PI	750	0.020	3.0	4900	0.0008	25	8.9
	R.PII		0.002	3.0		0.0002		
	R.PI	1000	0.020	3.0	5300	0.0008	40	6.7
	R.PII		0.002	5.0		0.0002		
EVEREST EVB15 800 m³/hr (13300 lpm) 3 HP/1500 rpm	R.PI	750	0.020	3.0	7800	0.0008	20	17.7
	R.PII		0.002	3.0		0.0002		
	R.PI	1000	0.020	3.0	8700	0.0008	20	13.3
	R.PII		0.002	5.0		0.0002		
	R.PI	1500	0.020	3.0	9800	0.0008	40	8.9
	R.PII		0.002	5.0		0.0002		
EVEREST EVB30 1670 m³/hr (27800 lpm) 5 HP/1500 rpm	R.PI	2000	0.020	5.0	10500	0.0008	40	6.7
	R.PII		0.002	7.5		0.0002		
	R.PI	5000	0.020	7.5	12000	0.0008	60	2.7
	R.PII		0.002	10		0.0002		
	R.PI	1500	0.020	3.0	16000	0.0008	20	18.5
	R.PII		0.002	5.0		0.0002		
EVEREST EVB50 2940 m³/hr (48800 lpm) 7.5 HP/1500 rpm	R.PI	2000	0.020	5.0	24700	0.0008	10	24.4
	R.PII		0.002	7.5		0.0002		
	R.PI	5000	0.020	7.5	35100	0.0008	20	9.8
	R.PII		0.002	10.0		0.0002		
	R.PI	7500	0.020	10.0	38700	0.0008	30	6.5
	R.PII		0.002	15.0		0.0002		
EVEREST EVB60 3910 m³/hr (65000 lpm) 10 HP/1500 rpm	R.PI	10000	0.020	15.0	40800	0.0008	40	4.9
	R.PII		0.002	20.0		0.0002		
	R.PI	5000	0.020	7.5	42800	0.0008	20	13.3
	R.PII		0.002	10.0		0.0002		
	R.PI	7500	0.020	10.0	48300	0.0008	20	8.7
	R.PII		0.002	15.0		0.0002		
	R.PI	10000	0.020	15.0	51600	0.0008	30	6.5
	R.PII		0.002	20.0		0.0002		
	R.PI	15000	0.020	10X2	55400	0.0008	40	4.3
	R.PII	7500X2	0.020	15X2		0.0002		

Notes

NOTES
(CONVERSIONS - lts/min * 0.06 = m³/hr : lts/min * 0.0353 = cfm : 1mBar *0.76 = 1 Torr)



ADVANTAGE OF USING ELECTRONIC VARIABLE SPEED CONTROL DRIVE WITH EVEREST BOOSTERS

At Everest we have developed special Electronic Variable Speed A.C., Motor drive for use with Everest Mechanical Booster Roots Booster Dry Vacuum Pump. These drives enhance the overall performance of the Boosters and offer various advantages for the trouble free operation of Boosters.

The major advantages are

- Booster can be started directly from atmosphere
- No need for separate pressure switch, by pass line or offloading valves
- Considerable saving in power
- Prevent over-heating of Boosters.
- Protect the Booster against overload and excessive pressure
- Offers complete protection to Motor against over voltage, under voltage, over current, over-heating, ground fault.
- Eliminates the needs of separate starter and overload relays for the Motor.
- Automatically adjust the speed of Booster between 100rpm to 3000rpm giving High pumping speeds with relatively low input power. A standard 1500rpm motor can be used for this purpose.

The Electronic Variable Frequency Drive is a microprocessor based electronic drive which is specially programmed to meet the demands of the Booster allowing it to operate directly from atmosphere along with suitable fore pump. Conventionally, the Boosters can be started only after achieving fore vacuum to the range of 30 50 Torr, as they are not recommended for direct discharge into the atmosphere. Use of Pressure Switch, Hydro kynamatic drive and by pass valves are necessary to prevent the overloading of the Booster. However with the installation of Electronic Drive all the conventional methods can be bypassed since the drive is programmed to regulate automatically the Booster speed, keeping the load on Motor within permissible

limits. This allows the Booster to start simultaneously with fore-pump.

Initially when the fore-pump and Booster are started the drive reduces the Booster speed to the predetermined levels and as the vacuum is created the Booster speed picks up to the final present speed, giving most optimum performance over the entire range. This drive can be set to achieve higher motor speeds than the Motor rated speeds since increase in frequency beyond 50 Hz., results in higher speed of the Motor without causing any harm to it. This function enables the Booster capacity to be enhanced by 50% to 90% of capacity at 1440rpm.

Since all the parameters are easily programmable, one can adjust the booster pumping speeds to match the system requirements easily and quickly. The drive limits the current to the Motor and safeguards the motor against over voltage, under voltage, electronic thermal, overheat ground fault... I.e. protects the Motor against all possible faults.

When the systems achieves a vacuum to the order of 1 Torr or better, the load on the Booster is reduced drastically and under such conditions the Booster speed can be easily increased without overloading Motor, resulting in higher pumping speeds.

External computer control over all aspects of booster performance is possible via RS485 serial interface built into the drive electronics. This enables the Booster to be integrated into any computer-controlled operating system.

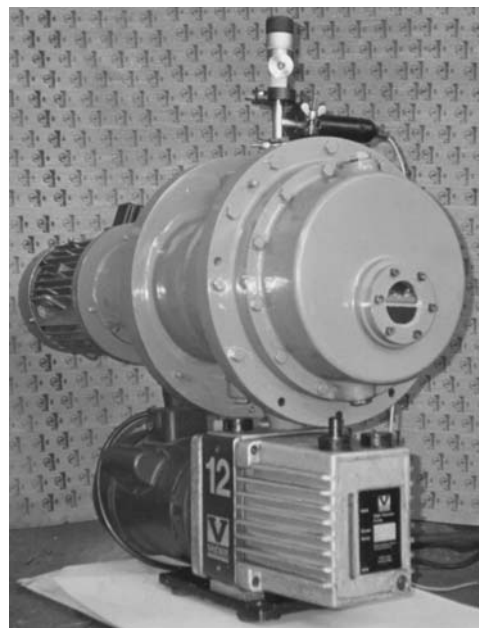

Notes



TYPICAL EVEREST BOOSTER ROTARY PUMP COMBINATION

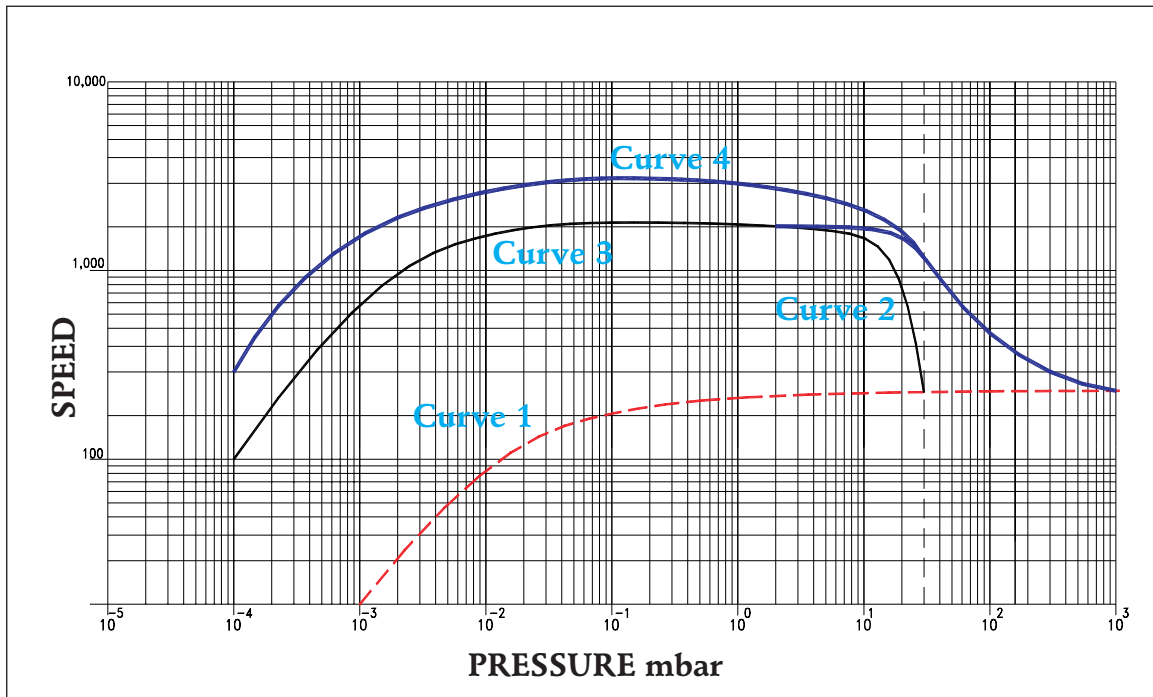

The above curves are a typical Everest Booster and Rotary Pump combination curves

Curve (1) indicates the speeds corresponding to various pressures for a double stage rotary pump.

Curve (2) indicates combination speed of Booster and Rotary Pump with pressure switch arrangement, in which Booster comes into operation at a set pressure of 30 Torr. During the initial period from atmosphere to 30 torr, the pumping speed is equal to the pumping speed of Rotary Pump only and higher speeds are achieved only beyond cut in pressure when the booster comes into operation.

Curve (3) indicates the speed of combination in which both the Booster and Rotary Pump are

started simultaneously from the atmosphere for this arrangement Auto speed control (variable frequency drive) or hydro kynamatic drive is necessary. The curve shows that the pumping speeds are relatively larger in the initial zone resulting in quick pump down time.

Curve (4) indicates the Booster Rotary Pump combination speed with Auto speed control drive set to 150% of Motor rated speed. The Drive automatically, in the range of pressures < 1 Torr, increases the Motor speed to 150% of its rated speed, boosting the overall pumping speed substantially.



VACUUM AND TERMS USED IN VACUUM TECHNOLOGY

What is Vacuum?

Vacuum is simply a pressure below atmosphere. To create vacuum in a system, a pump is required to remove mass (gas/vapor) from the system. The more mass is removed, lower is the pressure that exists inside the system. Various vacuum levels are defined depending upon the ultimate vacuum

Range	Absolute pressure range
Coarse Vacuum	10 - 760 Torr
Medium Vacuum	0.001 - 10 Torr
Fine Vacuum	10^{-3} - 10^{-7} Torr
Ultra High Vacuum	$< 10^{-7}$

Accommodation Coefficient (for free-molecule heat transfer). The rate of the energy actually transferred between impinging gas molecules and surface and the energy which would be theoretically transferred if the impinging molecules reached complete thermal equilibrium with the surface.

Back Streaming The direct flight of vapour molecules by scattering from the hot vapour jet or evaporation from hot nozzle parts in the direction of the mouth or intake port of a vapour pump.

Baffle A System of cooled walls, plates, or tubing placed near the inlet of a vapour pump to condense back streaming vapour at a temperature below that of the room and return the fluid to the boiler. The baffle plates may be located in the "Head" of the pump or in a separate housing attached to the inlet.

Booster Pump A vapour pump or a specially designed mechanical pump used between a vapour pump and a forepump to increase the maximum gas throughput which can be handled. The limiting or breaking forepressure of the booster at this maximum throughput must be appreciably greater than that of the vapour pump which it backs.

Cold Trap A vessel designed to hold a refrigerant, or cooled by coils in which a refrigerant circulates, inserted into a vacuum system so as to condense on its inner surface vapours present in the system.

Collision Rate The average number of collisions per second suffered by a molecule or other particle through a gas. Also called the collision frequency per molecule.

Compression Chamber The decreasing space within a mechanical pump in which the gas is compressed before discharging through the outlet.

Condensation Coefficient The ration of condensation rate to impingement rate.

Condenser Part of a vacuum system with large cooling surface (usually water cooled) for the condensation of large quantities of vapour (frequently water vapour)

Conductance (measured value) The throughput under steady-state limited conditions divided by the measured difference in pressure between two specified cross sections inside a pumping system.

Critical Backing Pressure The value of the backing pressure at any stated throughput which, if exceeded, causes an abrupt increase of pressure on the high vacuum side of the pump. In certain pumps the increase does not occur abruptly and this pressure is not precisely

determinable.

Diffusion Coefficient The absolute value of the ratio of the molecular flux per unit area to the concentration gradient of a gas diffusing through a gas or a porous medium where the molecular flux is evaluated across a surface perpendicular to the direction of the concentration gradient.

Diffusion Pump A vapour pump with a vapour stream of low density, capable of pumping gas with full efficiency at intake pressures below 10^2 Torr. The pumping action of each vapour jet occurs by the diffusion of gas molecules through the low, density scattered vapour into the denser forward moving core of a freely expanding vapour jet.

Ejector Pump A vapour pump with a dense vapour stream. The operating range depends on the pump fluid and is between 10^4 and 10^2 Torr. At higher pressures the mixing of entrained gas and vapour is effected by turbulence, at lower pressures by diffusion of gas into the vapour at the boundary of the dense vapour stream.

Forepressure The total pressure on the outlet side of a pump measured near the outlet port. Sometimes called the backing pressure.

Forepump The pump which produces the necessary fore-vacuum for a pump which is incapable of discharging gases at atmospheric pressure. Sometimes called the backing pump.

Fractionating Pump A multi-stage vapour pump in which the vapour supplied to the first stage (jet nearest the high vacuum) has been purged of the more volatile impurities, resulting from decomposition or contamination, by the partial condensation and refluxing of vapour in the condenser and the circulating of the condensed pump fluid through a series of boilers feeding the various stages so that the unwanted volatile constituents will be ejected in the stages closest to the fore-vacuum.

Free Air Displacement (for mechanical pumps) (a) Measured value the volume of air passed per unit time through a mechanical pump when the pressure on the intake and exhaust sides is equal to atmospheric pressure. Also called free air capacity.

(b) Calculated value product of the geometric volume of the compression chamber X atmospheric pressure X revs/min of the pump.

Gas Ballast The venting of the compression chamber of a mechanical pump to the atmosphere to prevent condensation of condensable vapours within the pump. Also called vented exhaust.

Impedance of Flow The reciprocal of the conductance. Also called resistance. $W = 1/L$.

Impingement Rate The number of molecules which strike a plane surface per square centimeter per second in a gas at rest. Also known as rate of incidence.

Inlet Pressure The total static pressure measured in a standard testing chamber by a vacuum gauge located near the inlet port of a vacuum pump (or: pressure in the inlet port of an operative vacuum pump.)

Leak In vacuum technology a hole, or porosity, in the wall of an enclosure capable of passing gas from one side of the wall to the other under action of a pressure or concentration differential existing across the wall.

Leak Rate In leak detection practice, leak rate is defined as the rate of flow (in pressure X volume units per unit time) through a leak with gas at a specified high pressure

Notes



(usually atmospheric pressure) on the inlet side and gas at a pressure on the exit side, which is low enough to have negligible effect on the rate of flow.

Liquid Ring Pump A pump for liquids or gases which entrains the fluid between the teeth of a pair of gears and the wall of the pump casing which fits closely around the gears except in the exhaust region where the teeth engage and the intake region where the teeth disengage.

Load of a Pump The quantity of gas (not including pump fluid vapour) in mass units flowing across the inlet port of a pump in unit time. Typical units are pounds per hour or grams per hour.

Mean free path (of any particle) The average distance that a particle travels between successive collisions with the other particles of an assembly. In vacuum technology the assembly of particles of interest comprises only the molecules in the gas phase.

Mean Molecular Velocity The average velocity of molecules in a gas at rest under equilibrium conditions.

Mechanical Pump A pump which moves the gas by the cyclic motion of a system of mechanical parts such as pistons, eccentric rotors, vanes, valves, etc.

Partial Pressure The pressure of a designated component of a gaseous mixture. The total pressure in a mixture of perfect gases is equal to the sum of the pressures exerted by the component gases were each to occupy the same volume by itself.

Pressure after Compression The pressure at the exhaust port of an operating vacuum pump.

Reciprocating Pump A pump which moves the gas by means of a system of reciprocating pistons and valves.

Residual Gas Pressure The pressure of all non-condensable gases in a container in which ultimate pressure has been obtained.

Residual Vapour Pressure The vapour pressure in a system which has reached the ultimate or limiting value of total pressure.

Reynolds Number As applied to the flow of gas through a circular tube the Reynold's number is a dimensionless quantity equal to the product of the gas density in grams per cubic centimeter times the flow velocity in centimeters per second times the tube diameter in centimeters times the flow velocity in centimeters per second times the tube diameter in centimeters divided by the viscosity coefficient in poises, $R_c = \rho v d / \eta$.

Roots (blower) Pump A rotary blower pump having a pair of two-lobe inter-engaging impellers of special design.

Rotary Blower Pump A pump without a discharge valve which moves the gas by the propelling action of one or more rapidly rotating members provided with lobes, blades, or vanes. Sometimes called a mechanical booster pump when used in series with a mechanical forepump. Rotary blowers are sometimes classified as either axial flow or cross flow type depending on the direction of flow of gas.

Sliding Vane Rotary Pump A liquid-sealed mechanical pump employing a rotor, stator and sliding vanes, dividing the pump chamber in three compartments.

Rotary Piston Pump A liquid-sealed mechanical pump having a cylindrical plunger (or piston) which is moved by an eccentric rotor in a sliding rotary motion with a liquid seal against the walls of a cylindrical stator and which divides the stator into two compartments by means of an attached vane or blade which slides through a slot in a

cylindrical bearing in the water wall.

Saturation Vapour Pressure The vapour pressure in an isolated system under equilibrium conditions in the presence of the condensed phase.

Separator (trap) Reservoir for separating two intermixed materials (e.g water-oil; oil-air) by centrifugal force or by deposition under the influence of gravity.

Sorption Pump A pump with a renewable trapping surface which reduces the partial pressure of gases by absorption, adsorption, or chemisorptions.

Specific Speed Pumping speed of a diffusion pump per unit area of nozzle clearance area.

Speed of Exhaust The magnitude of the rate of reduction of pressure in the system multiplied by the volume and divided by the measured pressure.

Speed of a Pump The pumping speed for a given gas is the ratio of the throughput of that gas to the partial pressure of that gas at a specified point near the mouth (or inlet port) of a pump.

Sputtering Pump A gettering pump in which the gettering surface is produced by sputtering the getter material in an electric gas discharge.

Standard Atmosphere a) the standard atmosphere, or normal atmosphere is defined (independently of barometric height) as a pressure of 1,013,250 dyn/cm².

(b) the normal atmosphere has also been defined as the pressure exerted by a mercury column 760 mm in height at 0°C under standard acceleration of gravity of 980-665 cm/sec². Assuming a density of mercury at 0°C of 13-59509 g/cm³, this is equal to 1,013,249 dyn/cm².

Throughput Under conditions of steady-state conservative flow the throughput across the entrance to a pipe is equal to the throughput at the exit. In this case the throughput can be defined as the quantity of gas flowing through a pipe in pressure X volume units per unit time at room temperature.

Time of Evacuation The time required to pump a given system from atmospheric pressure to a specified pressure. Also known as pump-down time.

Torr The torr is defined as 1/760 of a standard atmosphere or 1,013,250 / 760 dyn/cm². This is equivalent to defining the Torr as 1333.22 microbars and differs by only one part in seven million from the International Standard millimetre of mercury. 1 mm Hg = 1.00000014 Torr.

Total Pressure Total pressure usually refers to the pressure determined by all of the molecular species crossing the imaginary surface.

Ultimate Pressure The limiting pressure approached in the vacuum system after sufficient pumping time to establish that further reductions in pressure will be negligible.

Vapour A gas whose temperature is below its critical temperature, so that it can be condensed to the liquid or solid state by increase of pressure alone.

Vapour Pressure (a) the sum of the partial pressures of all the vapours in a system.

(b) the partial pressure of a specified vapour.

Vapour (stream) Pump Any pump employing a vapour jet as the pumping means. Applies to ejector pumps as well as to diffusion pumps.

Notes



**APPENDIX I
Composition of Atmospheric Air**

	% of weight	%of volume	Partial pressure, mbar
N ₂	75.51	78.1	792
O ₂	23.01	20.93	212
Ar	1.29	0.93	9.47
CO ₂	0.04	0.03	0.31
Ne	1.2x10 ⁻²	1.8x10 ⁻³	1.9x10 ⁻²
He	7x10 ⁻⁵	7x10 ⁻⁵	5.3x10 ⁻³
CH ₄	2x10 ⁻⁴	2x10 ⁻⁴	2x10 ⁻³
Kr	3x10 ⁻⁴	1.1x10 ⁻⁴	1.1x10 ⁻³
N ₂ O	6x10 ⁻⁵	5x10 ⁻⁵	5x10 ⁻⁴
H ₂	5x10 ⁻⁶	5x10 ⁻⁵	5x10 ⁻⁴
Xe	4x10 ⁻⁵	8.7x10 ⁻⁶	9x10 ⁻⁵
O ₃	9x10 ⁻⁶	7x10 ⁻⁶	7x10 ⁻⁵
	100 %	100 %	1,013

50% RH at 20°C		
	1.6	1.15
		11.7

Note RH = Relative Humidity
Taking into account the relative humidity, the total pressure as read by the barometer amounts to 1,013 + 11.7 = 1,025mbar

Notes

**APPENDIX II
Vacuum Units and Formulae**

Units of Pump Speed (Volume / Time)

1 L/s	= 2.12 ft ³ /min	= 3.6 m ³ /h
1 ft ³ /min	= 0.47 L/s	= 1.69 m ³ /h
1 L/m	= 0.035 ft ³ /min	= 0.06 m ³ /hr

Units of Gas Quantities PV

1 molar volume	= 22.41 L (at standard conditions-STP)
1 mol	= 6.023 x 10 ²³ molecules
1 L.atm	= 2.69 x 10 ²² molecules
1 std cm ³	= 2.69 x 10 ¹⁹ molecules
1 torr.L	= 3.53 x 10 ¹⁹ molecules
1 std cm ³	= 0.76 torr.L
1 std cm ³	= 1 atm . Cm ³
1 std ft ³	= 7.6 x 10 ²³ molecules

Standard conditions are 1 atm at 273° K

Units of Throughput (Q = PV/Time)

(PV = work; work/time = power)	
1 std cm ³ /s	= 760 μm (Hg) L/s
	= 1.6 torr.ft ³ /min
1 torr ft ³ /min	= 0.62 std cm ³ /s
	= 472 μm (Hg) L/s
1 um (Hg.) L/s	= 1.32 x 10 ⁻³ std cm ³ /s
	= 2.12 x 10 ⁻³ torr ft ³ /min

Ideal Gas Law

P = nkT
n : No. of molecules
k : Boltzmann's constant
T : Absolute temperature
(P₁V₁/T₁) = (P₂V₂/T₂)

Molecular Velocity

Root mean square velocity C = (3 kT/m)^{1/2}
= 1.58 X 10⁴ (T/M)^{1/2} cm/sec
m : molecular mass
M : Molecular weight
Average velocity C_a = (8 kT / m)^{1/2}
= 1.46 X 10⁴ (T. M)^{1/2} cm/sec
Most Probable velocity C_p = (2 kT/m)^{1/2}

= 1.29 X 10⁴ (T/M)^{1/2} cm/sec

Impingement Rate (v)

V = P(2 mkT)^{1/2}
= 3.5 X 10²² p (MT)^{1/2} molecules/sec cm²

p in Torr

Mean Free Path (λ)

= 1/2^{1/2} n⁻² = Molecular diameter
= 5 X 10⁻³ / P (Torr) cm

Flow Regimes

Viscous Flow :R < 1200 and K_n < 0.01
Turbulent Flow :R > 2200 R: Reynolds's number
Molecular Flow : K_n > 1 K_n = λ/d Knudsen's number

Conductance

Conductance : C = q/(P₂-P₁)
Conductance's in parallel: C_T = C₁ + C₂ + C₃ +
Conductance's in series : 1/ C_T = 1/C₁ + 1/C₂ + 1/C₃ + ...

Viscous Conductance, long circular tube:

C_v = (d⁴ /128 λ) (P₁ + P₂)/2
= (182 d⁴/l) Pav l/s for air at 20°C

d : Tube diameter ,cm

l : Tube length ,cm

λ : coefficient of viscosity, poise

Molecular Conductance ,long circular tube

C = (2 kT/m)^{1/2} (d³/6 l)
= 12.1 d³/l for air at 20°C

Molecular conductance ,circular tubes of arbitrary length

C = (12.1 d³ / l) l/s
= clausing's factor
= [15(1/d) + 12 (1/d)] / [20 + 32 (1/d) + 12 (1/d)]

Molecular conductance ,small aperture

C = 3.64 A (T/M)^{1/2}
= 11.6 A l/s for air at 20°C

A : Area of aperture ,cm²

Molecular conductance ,long rectangular duct

C = [30 a²b² / (a+b) l] K
Where K is given by
b/a 1.0 0.8 0.6 0.4 0.2 0.1
K 1.1 1.12 1.13 1.17 1.29 1.44

Pumping Speed: S = q/p

Effective Pumping Speed

1/ S_{eff} = 1/S + 1/C
S_{eff} = S C / (S + C)

PumpDown Time

(viscous Region for Pressure ≤ 10⁻³ Torr)

t = K .2.3 (V/S) log (p_i/ p_u)
t = Time .minutes
V = volume, liters
S = Effective Pumping Speed, l/m
p_i = Intial Pressure ,Torr
P₂ = Final Pressure, Torr
k = Factor depending on pressure range
Pressure Range K
760-1 Torr 1.1
1 0.01 Torr 1.5
0.1- 0.001 Torr 4

PumpDown Time (Molecular Region, Theoretical)

t = (V/S_{eff}) 2.3 log [(p_i p_u)/((p p_u)]
V = Volume of Chamber ,liters
S_{eff} = Effective pumping speed at the chamber , l/s
p_i = Intial Pressure ,Torr
p = Pressure after t sec, Torr
p_u = Ultimate pressure in the chamber
p_u = Q_g / S_{eff}
Gas Load Q_g = Q_l + Q_o + Q_v + Q_p
Q_l = Gas load due to real leaks
Q_o = Gas load due to outgassing
Q_v = Gas load due to vapor pressure



CONVERSION TABLES

P	PRESSURE						
	Torr	mbar	bar	Pa	atm	psi	kg/cm ²
Torr	1	1.33	1.33 x 10 ⁻³	133.32	1.32x10 ⁻³	1.90x10 ⁻²	1.34x10 ⁻³
mbar	0.75	1	1x10 ⁻³	100	9.87x10 ⁻⁴	1.40x10 ⁻²	9.86x10 ⁻⁴
bar	750.06	1000	1	1x10 ⁻⁵	0.987	14.5	1.022
Pascal	7.5x10 ⁻³	0.01	1x10 ⁻⁵	1	9.87x10 ⁻⁶	1.45x10 ⁻⁴	1.02x10 ⁻⁵
atm	760	1013	1.013	101325	1	14.69	1.035
psi	51.71	68.95	0.069	6895	0.068	1	0.07
kg/cm ²	733.95	978.64	0.979	97861	0.965	14.19	1

S/C	PUMPING SPEED/CONDUCTANCE			
	Lit./Sec.	lit/min	m ³ /hr	Cu.ft/min
Lit/sec	1	60	3.6	2.119
Lit/min	0.017	1	0.06	0.035
m ³ /hr	0.278	16.67	1	0.59
Cu.ft/min	0.47	28.32	1.69	1

q/qL	THROUGHPUT / LEAK RATE				
	Torr l/sec	mbar l/sec	W	std.cc/sec	std.cc/min
Torr l/sec	1	1.33	0.133	1.32	78.9
mbar l/sec	0.75	1	0.1	0.99	59.2
pa m ³ /sec (W)	7.5	10	1	9.87	592
std.cc/sec	0.76	1.01	0.101	1	60
std.cc/min	1.27x10 ⁻²	1.69x10 ⁻²	1.69x10 ⁻²	1.7x10 ⁻²	1

**WE JUST DON'T
OFFER BLOWERS & BOOSTERS,
WE OFFER SOLUTIONS!**

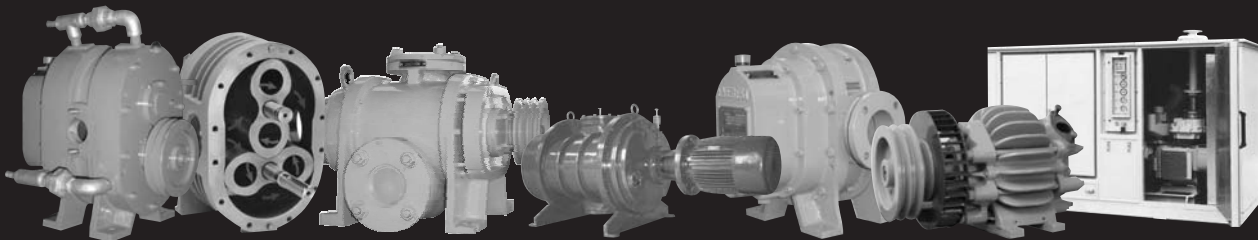

WATER COOLED BIO GAS ~ GAS AQUA SERIES VACUUM BOOSTER AIR COOLED DRY VANE PUMP ACOUSTIC ENCLOSURE

TWIN LOBE ROTARY AIR & GAS BLOWERS, BOOSTERS, PUMPS AND ACOUSTIC ENCLOSURES

Our technology is so flexible, we can custom manufacture "Special Air Blowers & Enclosures" by alloying and cross linking diverse designs to suit individual requirements and import substitutes.

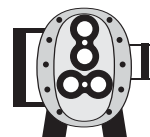

EVEREST Transmission

B-44, Mayapuri Industrial Area, Phase-I, New Delhi 110 064, India. Telefax: 91-11-28116307, 28114944, 28114955, 28117469 Email: info@everestblowers.com

www.everestblowers.com

VACUUM BOOSTERS

EVEREST

EXTENSIVELY USED FOR

Evaporative Concentration, Vacuum Distillation, Polymerization, Crystallization, Vacuum Impregnation, Vacuum Drying, Sterilization, Vacuum Cooling, Object Metallising, Roll Metallisation, Semi-conductor Processing, Manufacture of Vacuum & Microwave Tubes, Manufacture of GLS Automotive & Miniature Lamps, Tube Light Production, Sintering, Brazing, Electron Beam Welding, Heat Treatment, Ionic Nitriding, Tool Coating, Vacuum Casting, Degassing & Refining, Plasma Welding, Evaporation, Sputtering, Space Research and Development Applications.

MAJOR INDUSTRIES SERVED

Chemical & Pharmaceutical, Food Processing, Industrial Processing, Vacuum Furnace, Semi-conductor, Electrical and Lighting Industries.

TECHNICAL SPECIFICATIONS

MODEL	SPEED (SWEEP VOLUME @ 1500 RPM) (Pr. RANGE 10-10 ⁻³ TORR) LPM (m ³ /hr)	RATED MOTOR HP (1500 RPM)	FLANGE DIAMETER (MM) ISO CODE	MAX CUT IN Pr AT INLET (TORR)	RECOMMENDED BACKING PUMP (LPM)
EVB05	6700 (400)	2	145 (ISO 80)	50	500 - 1000
EVB15	13300 (800)	3	165 (ISO 100)	30	1000 - 3000
EVB30	27800 (1670)	5	225 (ISO 160)	30	3000 - 5000
EVB50	48800 (2930)	7.5	225 (ISO 160)	20	5000 - 10000
EVB60*	65100 (3900)	7.5/10	225 (ISO 160)	30/60	2 X (5000 - 10000)

* At 2000 rpm

The cut in pressures indicated, correspond to the Motor power. For higher range, refer Everest.

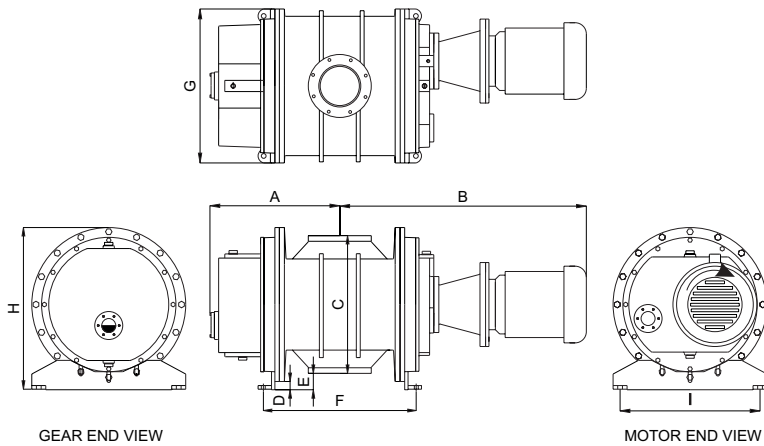

MODEL	A	B	C	D	E	F	G	H	I
EVB05	232	565	236	30	83	300	342	371	280
EVB15	264	646	320	38	78	350	400	439	280
EVB30	390	810	330	36	101	533	460	496	410
EVB50	455	881	492	30	59	546	550	580	500
EVB60	455	919	492	30	59	546	550	580	500

All dimensions are in mm.



Wide range of Booster Pumps from 2000 LPM to 100000 LPM are commercially available. For further clarifications, contact our technical team who shall be glad to assist you to overcome application problems.

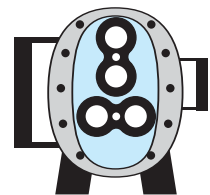

B-44, Mayapuri Industrial Area, Phase-I, New Delhi 110 064, India
 Telefax: 91-11-28116307, 28114944, 28114955, 28117469 Email: info@everestblowers.com Web: www.everestblowers.com

EVEREST Transmission

www.everestblowers.com