

EVEREST TWIN LOBE POSITIVE DISPLACEMENT AIR BLOWERS

Everest Blowers manufactures a complete range of standards blowers available for flow rates from 10 m³/hr upto 10,000 m³/hr in single stage and up to any capacity in parallel configuration, for working pressure upto 1kg/cm.sq. They are available in form of complete package units (Ready to install) or as bare shaft units for replacement.

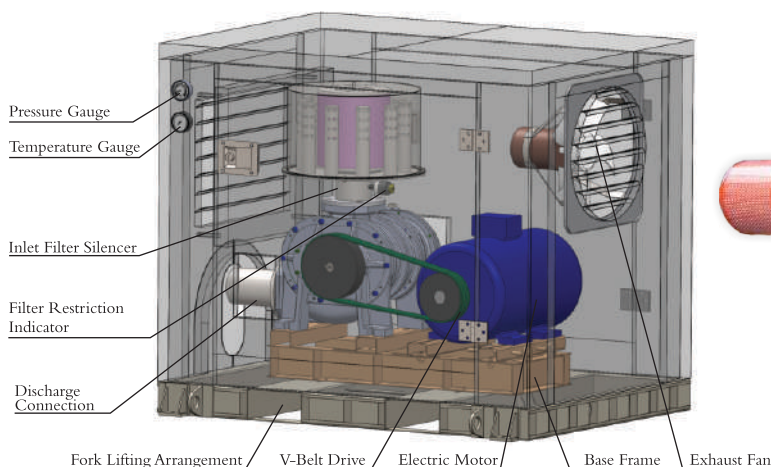

**EVEREST
BLOWERS MEANS
TROUBLE FREE
COMPRESSION**



APPLICATIONS

- **Water Treatment Plant** for backwashing of filter/mixed beds.
- **Effluent Treatment Plant** for diffused aeration and agitation of effluent.
- **Sewage Treatment Plant** for diffused aeration and agitation of sewage.
- **Cement Plant** for Blending, Aeration, Fluidization, Conveying.
- **Aquaculture** for maintaining the dissolved Oxygen level.
- **Chemical Plant** For supplying of process air.
- **Electroplating Plant** for Oil Free air agitation of electrolyte.
- **Paper Plant** Knife edge coating, Drying, Conveying, Vacuum pickup.
- **Pneumatic Conveying** Vacuum, Pressure and Combination Conveying of cereals, cement, husk, baggase, granules, powders and other similar material.

NEW FEATURES

- 100% oil free air delivery.
- Factory engineered, factory guaranteed, superior product.
- Alloy steel hardened and ground timing gears.
- Anti-friction bearings.
- Rigid one piece CI casing and side plates.
- Easy rotor timing setting.
- No vanes, valves or rings to wear.
- Large inlet and outlet connections for minimum loss.
- Improved volumetric efficiency and reduced operating temperatures.
- Alloy steel toughened shafts ground to close tolerances.

Experience the quality, class and longevity of positive displacement by Everest Blowers.



PERFORMANCE TABLE TWINLOBE ROTARY AIR BLOWERS

MODEL	AIR COOLED														WATER COOLED							
	SPEED	1000 mmWC		2000 mmWC		3000 mmWC		4000 mmWC		5000 mmWC		6000 mmWC		7000 mmWC		8000 mmWC		9000 mmWC		10000 mmWC		
	RPM	m ³ /hr	BKW	m ³ /hr	BKW	m ³ /hr	BKW	m ³ /hr	BKW	m ³ /hr	BKW	m ³ /hr	BKW	m ³ /hr	BKW	m ³ /hr	BKW	m ³ /hr	BKW	m ³ /hr	BKW	
M422	1600	26	0.2	19	0.3	14	0.5	9	0.6	5	0.7	2	0.8	0	0.9							
	5000	119	0.7	112	1.1	106	1.4	102	1.8	98	2.2	94	2.5	91	2.9							
M450	700	45	0.4	34	0.6	25	0.8	18	1.0	12	1.2	6	1.4	1	1.5							
	2400			207	2.0	198	2.6	191	3.3	185	4.0	179	4.6	174	5.3							
M44	700	80	0.5	69	0.8	61	1.0	55	1.3	49	1.6	44	1.9	39	2.2							
	2800	394	1.9	384	3.0	376	4.2	369	5.3	348	6.4											
M5125	700	147	0.9	124	1.5	107	2.0	92	2.6	79	3.1	67	3.7	57	4.2							
	2800	754	3.7	731	5.9	714	8.1	699	10.3	686	12.5	674	14.7	663	16.9							
M5175	700	206	1.1	174	1.9	150	2.7	129	3.4	111	4.2	94	5.0	79	5.8							
	2800	1056	4.5	1024	7.6	999	10.7	978	13.8	960	16.9											
67	700	286	1.6	241	2.7	207	3.7	179	4.8	154	5.9	131	6.9	110	8.0	90	9.1	72	10.1	54	11.2	
	2400	1239	5.4	1195	9.1	1161	12.8	1132	16.4	1107	20.1	1084	23.7	1063	27.4	1044	31.1	1025	34.7			
610	700	382	1.9	323	3.4	277	4.8	239	6.2	205	7.7	175	9.1	147	10.5	120	11.9	96	13.4	73	14.8	
	2400	1656	6.7	1597	11.6	1551	16.5	1513	21.3	1479	26.2	1449	31.1									
615	700	585	2.7	502	4.8	438	7.0	384	9.1	337	11.2	294	13.4	255	15.5	218	17.6	184	19.8	151	21.9	
	2400	2492	9.3	2409	16.6	2345	23.9	2291	31.2													

Blue cells for FAD indicate next higher standard line size recommended. Red value for BKW indicate suitable for Intermittent Duty Applications only & not fit for continuous 24/7 running.

MODEL	M422	M450	M44	M5125	M5175	67	610	615
LINE SIZE (NB)	32	40	65	80	100	100	125	150

DESIGN & TECHNICAL FEATURES TWIN-LOBE BLOWERS

Seal:
Low-wear, non-contacting, labyrinth-type seals ensure performance and long life.

Shafts:
Rotor shafts are alloy steel forgings that allow higher operating pressures and rotation speeds

Rotors:
Made from cast iron or SG iron stainless steel with stiff design for maximum life. By CNC and 3D machinery control to ensure the highest performance providing with trouble-free performance and durability.

Casing:
All Everest Blowers units are single-piece construction and precision machined cast iron, with ribs for strength and consistent thermal behavior.

Bearings:
All Everest Blower units are using SKF/FAG Eqv. bearings with long life. Anti-friction type vary with machine.

Timing Gears:
Forged steel gears with hardened and ground spur teeth to reduced vibrations and ensures accurate rotor to rotor timings for smooth and efficient operation.

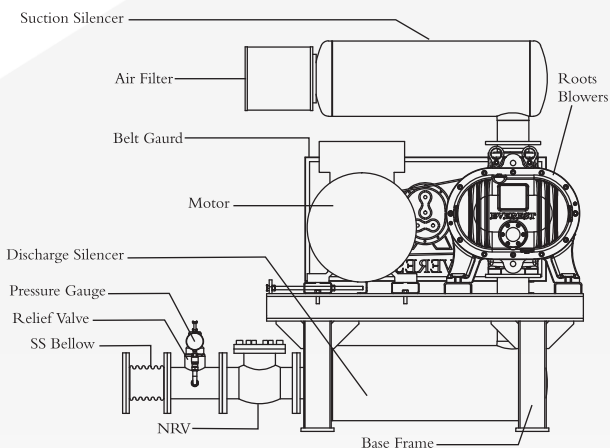
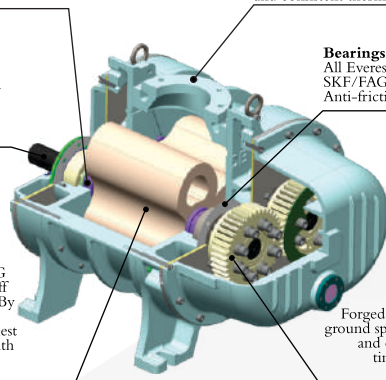

* Accessories indicated in diagram are as per customer requirement

Corporate Office
+91 11 45457777

Sales
enquiry@everestblowers.com

Corporate Office
B-44, Mayapuri Industrial Area, Phase 1, New Delhi 110064, India
Factory
Plot No. 82-83, Sector 16, HSIIDC, Bahadurgarh 124507, Haryana, India
ISO 9001:2015 | ISO14001:2015 | OHSAS 18001:2007 Certified

Web
www.everestblowers.com



Marketed & Serviced By:

We don't just offer
"Blowers, Vacuum Pumps and Compressors"
we offer **Energy Saving Solutions !!!**