

The World of Compressed Air Industry  
Now Gets Simplified Solutions !!!!

# Heli-Hybrid

## Blower & Vacuum Pump Series



---

Everest Heli-Hybrid Blowers is the original rotary Helical Blower, providing proven results for more than 20 years. This highly efficient Helical Blower provides quality and dependability in multiple applications.

---



[www.everestblowers.com](http://www.everestblowers.com)

## What We Do ?

Everest Blowers has been designing and manufacturing superior quality compressed air solutions since 1980 - with 4 decades of experience developing high quality Roots Blowers. In the tough & global market - we strongly adhere to competitive pricing, sturdiness, efficiency, innovation and ease of maintenance. Over the past years we have thrived to lead the Indian and Asian Market, earning world-wide credibility and have exported our blowers to over 38 countries world-wide.

We believe that our reputation for reliable products, excellent services and timely deliveries has helped us grow into a globally recognized brand enabling success for our customers/users. We Aim to preserve production standardization making sure we remain at par with other worldwide manufacturers.

## Industrial Compressed Air Solutions

### Types of PD Blowers Under Everest Umbrella

- Bilobe Blower (Air, Gas, Vacuum)
- Trilobe Blower (Air, Gas, Vacuum)
- **Quiet Hybrid Helical (Heli-Hybrid) Blower (Air, Gas, Vacuum)**
- Gearless Turbo Blower
- Geared Turbo Blower
- Multistage Centrifugal Blower
- Single and Double Stage Centrifugal Blower
- Acoustic Hoods | Enclosures

Reliable **QUIET**  
**ENERGY SAVINGS**  
**EFFICIENT**  
*High Performance*

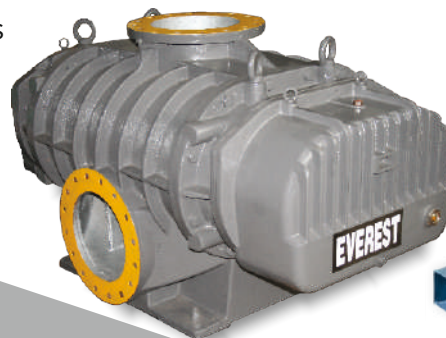



## VISION

### Vision

To become top solution provider by being a prominent and trusted brand for:

- Positive Displacement Blowers in the world
- Low Pressure Compressors in India

*Everest-First in Sight, First in Mind.....*

## CORE VALUES

### Core Values

- Customer Focus
- Respect for Individuals
- Ethics & Integrity
- Sincerity at workplace
- Self motivated individuals
- Transparent Communication Channels
- Institution Building thru skill enhancement

## FEATURES - HELI-HYBRID SERIES

- Innovative and revolutionary PD Blower design.
- Higher flow rate compared to straight lobe blower 12 to 15% for same RPM & Delta Pressure.
- Reduction in power 8 to 12% for same capacity.
- Considerable reduction in vibrations compare to straight lobe machines, which results reducing the stresses on discharge pipeline & base frame.
- Reduce noise level up to 3-8 dBA.
- Dual oil splash lubrication.
- Anti-friction bearings.
- Ground & Hardened taper timing gears.
- Heavy duty design for reduced to down time.
- Advanced oil/air seals for reliable air delivery.
- Designed for dusty, abrasive environments.
- Decades of proven results !

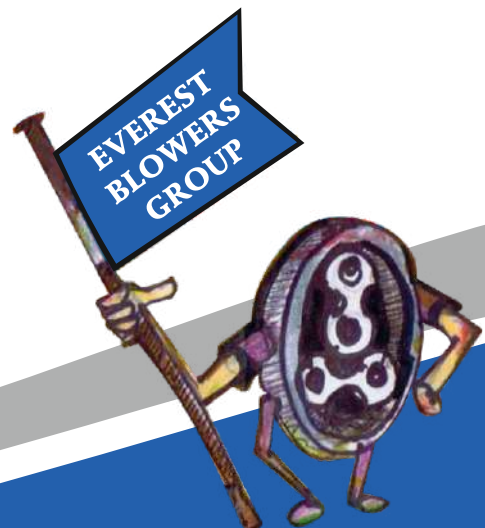

It's all about...

# Saving Money



## TOTAL COST OF BLOWER OWNERSHIP

- Energy
  - Maintenance
  - Investment
- Energy consumption is typically the largest cost of ownership.
  - Save BIG with best-in-class energy efficiency.
  - Lower your bottom line, increase your profits.

### Innovation Working for You!

In many comparable applications, the Heli-Hybrid Blower operates more efficiently than other straight-lobe blowers. By requiring less brake kilowatt (BKW) energy operating cost can be realized and greatly reduced.



INVEST WISELY  
REDUCE ENERGY

*Save Money*

## HELI-HYBRID VS. STRAIGHT LOBE

BLOWER TECHNOLOGY	BKW USED @ 7000 mmWC	ENERGY COST PER YEAR
Standard Straight Lobe	65.32	₹40,53,106
Heli-Hybrid	58.47	₹36,28,064

**₹4,25,042**  
ANNUAL SAVINGS

Calculations based on the cost of providing 2500 m<sup>3</sup>/hr of air @ 7000 mmWC for kW saving/hour x Rs. 8.5/unit x 20 hours/day x 365 running/annum.

**PAYBACK PERIOD  
7-8 MONTHS**

FLOW COMPARISON AT SAME RPM AND DIFF. DELTA PRESSURE

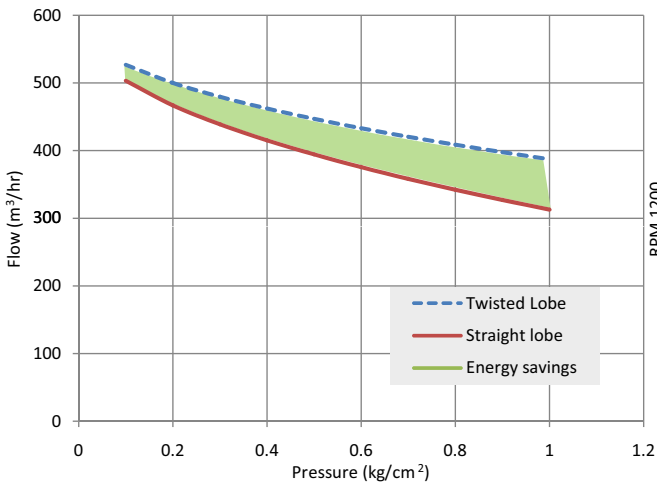

POWER COMPARISON AT SAME FLOW RATE AND DIFF. DELTA PRESSURE

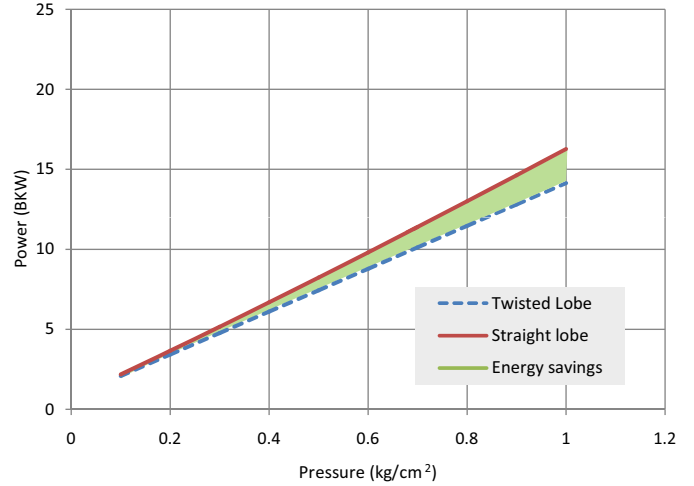

**HELI-HYBRID BLOWER COMPLETE SET**

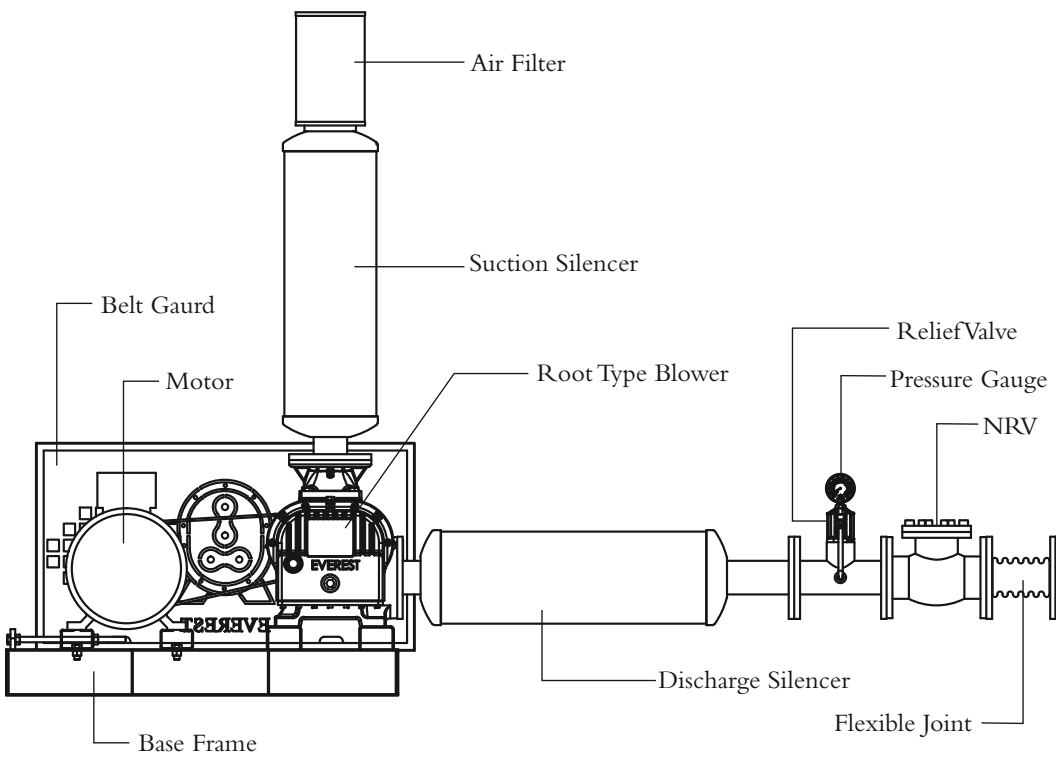

**TYPE MODEL HELI-HYBRID SERIES**

- HHL65
- HHL100
- HHL150
- HHL200
- HHL250
- HHL275
- HHL300
- HHL350

**ADVANTAGE**

Wide range of volume, pressure & horse power

- Line Size : 65NB to 450NB (2.5" to 18")
- Pressure : 1000mmWC to 10000mmWC (Air/Water Cooled)
- Horse Power : 1 HP to 700 HP (0.75 kW to 522 kW)
- Capacity : 60 to 17901 m³/hr

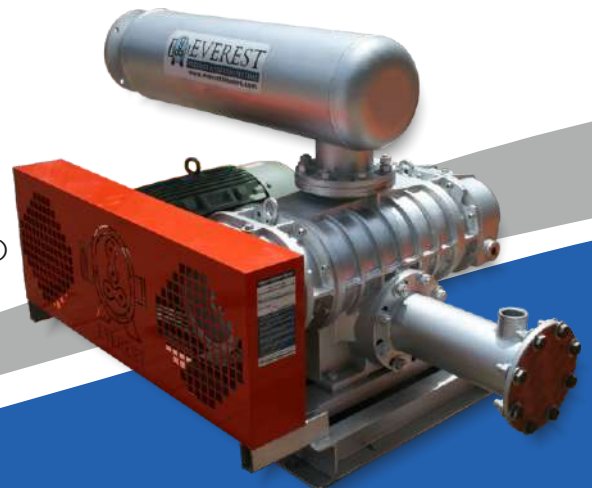

PERFORMANCE TABLE HELI-HYBRID ROTARY BLOWERS

MODEL	AIR COOLED																WATER COOLED OR SYNTHETIC OIL LUBRICATION				
	SPEED	1000 mmWC		2000 mmWC		3000 mmWC		4000 mmWC		5000 mmWC		6000 mmWC		7000 mmWC		8000 mmWC		9000 mmWC		10000 mmWC	
	RPM	m³/hr	BKW	m³/hr	BKW	m³/hr	BKW	m³/hr	BKW	m³/hr	BKW	m³/hr	BKW	m³/hr	BKW	m³/hr	BKW	m³/hr	BKW	m³/hr	BKW
HHL65	800	125	0.8	113	1.2	103	1.6	95	2.0	88	2.5	81	2.9	76	3.3	70	3.7	65	4.1	60	4.6
	1100	183	1.1	171	1.7	161	2.2	153	2.8	146	3.4	140	4.0	134	4.5	128	5.1	123	5.7	118	6.3
	1400	241	1.4	229	2.1	219	2.8	211	3.6	204	4.3	198	5.0	192	5.8	186	6.5	181	7.3	176	8.0
	1700	299	1.7	287	2.6	277	3.4	269	4.3	262	5.2	256	6.1	251	7.0	245	7.9	239	8.8	234	9.7
	2100	377	2.0	364	3.2	355	4.3	347	5.4	340	6.5	333	7.6	328	8.7	322	9.8	317	10.9	312	12.0
	2500	454	2.4	442	3.8	432	5.1	424	6.4	417	7.7	411	9.0	406	10.3	400	11.6	394	13.0		
	2800			500	4.2	491	5.7	483	7.2	475	8.6	469	10.1	464	11.6	458	13.0				
HHL100	800	330	1.7	303	2.7	282	3.8	265	4.9	250	6.0	236	7.0	223	8.1	212	9.2	200	10.2	190	11.3
	1100	478	2.3	451	3.8	430	5.2	413	6.7	398	8.2	384	9.7	371	11.1	359	12.6	348	14.1	338	15.6
	1400	625	2.9	599	4.8	578	6.7	561	8.5	546	10.4	532	12.3	519	14.2	507	16.0	496	17.9	486	19.8
	1700	773	3.5	747	5.8	726	8.1	709	10.4	693	12.7	680	14.9	667	17.2	655	19.5	644	21.8	634	24.0
	2000	921	4.2	894	6.8	874	9.5	857	12.2	841	14.9	828	17.6	815	20.2	803	22.9	792	25.6	782	28.3
	2500	1168	5.2	1141	8.6	1120	11.9	1103	15.3	1088	18.6	1074	22.0	1061	25.3						
	2800	1316	5.8	1289	9.6	1268	13.3	1251	17.1	1236	20.8	1222	24.6	1209	28.3						
HHL150	800	910	3.4	880	6.1	856	8.8	837	11.4	819	14.1	804	16.8	789	19.4	776	22.1	763	24.8	752	27.5
	1000	1156	4.3	1125	7.6	1102	11.0	1082	14.3	1065	17.6	1050	21.0	1035	24.3	1022	27.6	1009	31.0	997	34.3
	1200	1401	5.1	1371	9.1	1348	13.1	1328	17.1	1311	21.2	1295	25.2	1281	29.2	1268	33.2	1255	37.2	1243	41.2
	1400	1647	6.0	1617	10.7	1594	15.3	1574	20.0	1557	24.7	1541	29.4	1527	34.0	1513	38.7	1501	43.4	1489	48.1
	1600	1893	6.8	1863	12.2	1839	17.5	1820	22.9	1803	28.2	1787	33.5	1773	38.9	1759	44.2	1747	49.6	1735	54.9
	1800	2139	7.7	2108	13.7	2085	19.7	2066	25.7	2048	31.7	2033	37.7	2018	43.8	2005	49.8	1992	55.8	1980	61.8
	2000	2385	8.5	2354	15.2	2331	21.9	2311	28.6	2294	35.3	2278	41.9	2264	48.6	2251	55.3	2238	62.0	2226	68.7
HHL200	800	1486	6.5	1425	11.0	1379	15.4	1340	19.8	1306	24.3	1275	28.7	1246	33.1	1219	37.6	1194	42.0	1171	46.4
	1000	1894	8.2	1833	13.7	1787	19.2	1748	24.8	1714	30.3	1682	35.9	1654	41.4	1627	46.9	1602	52.5	1578	58.0
	1200	2302	9.8	2241	16.4	2195	23.1	2156	29.7	2122	36.4	2090	43.0	2062	49.7	2035	56.3	2010	63.0	1986	69.6
	1400	2710	11.4	2649	19.2	2603	26.9	2564	34.7	2529	42.5	2498	50.2	2470	58.0	2443	65.7	2418	73.5	2394	81.2
	1500	2914	12.2	2853	20.5	2807	28.9	2768	37.2	2733	45.5	2702	53.8	2674	62.1	2647	70.4	2622	78.7	2598	87.1
	1700	3322	13.9	3261	23.3	3215	32.7	3176	42.1	3141	51.5	3110	61.0	3082	70.4	3055	79.8	3030	89.2	3006	98.7
	1800	3526	14.7	3465	24.7	3419	34.6	3380	44.6	3345	54.6	3314	64.6	3286	74.5	3259	84.5	3234	94.5	3210	104.5
HHL250	800	2329	8.9	2260	15.7	2207	22.4	2162	29.2	2122	36.0	2087	42.8	2054	49.6	2023	56.4	1995	63.1	1967	69.9
	1000	2953	11.1	2884	19.6	2831	28.1	2786	36.5	2746	45.0	2711	53.5	2678	62.0	2647	70.4	2619	78.9	2591	87.4
	1200	3577	13.3	3508	23.5	3455	33.7	3410	43.8	3371	54.0	3335	64.2	3302	74.4	3272	84.5	3243	94.7	3216	104.9
	1400	4202	15.5	4132	27.4	4079	39.3	4034	51.1	3995	63.0	3959	74.9	3926	86.8	3896	98.6	3867	110.5	3840	122.4
	1600	4826	17.7	4756	31.3	4703	44.9	4658	58.4	4619	72.0	4583	85.6	4550	99.2	4520	112.7	4491	126.3	4464	139.9
	1700	5138	18.9	5068	33.3	5015	47.7	4970	62.1	4931	76.5	4895	90.9	4862	105.3	4832	119.8	4803	134.2	4776	148.6
	1800	5450	20.0	5381	35.2	5327	50.5	5283	65.8	5243	81.0	5207	96.3	5174	111.5	5144	126.8	5115	142.1	5088	157.3
HHL275	800	3776	14.4	3690	25.2	3624	36.1	3569	46.9	3520	57.7	3475	68.5	3435	79.4	3397	90.2	3361	101.0	3327	111.8
	1000	4772	18.0	4686	31.5	4620	45.1	4565	58.6	4516	72.1	4471	85.7	4431	99.2	4393	112.7	4357	126.3	4323	139.8
	1200	5768	21.6	5682	37.8	5616	54.1	5561	70.3	5512	86.6	5467	102.8	5427	119.0	5389	135.3	5353	151.5	5319	167.8
	1400	6765	25.2	6678	44.2	6612	63.1	6557	82.0	6508	101.0	6463	119.9	6423	138.9	6385	157.8	6349	176.8	6315	195.7
	1600	7761	28.8	7675	50.5	7609	72.1	7553	93.8	7504	115.4	7459	137.1	7419	158.7	7381	180.4	7345	202.0	7311	223.7
	1700	8259	30.6	8173	53.6	8107	76.6	8051	99.6	8002	122.6	7958	145.6	7917	168.6	7879	191.7	7843	214.7		
	1800	8757	32.4	8671	56.8	8605	81.1	8549	105.5	8500	129.9	8456	154.2	8415	178.6	8377	202.9	8341	227.3		

Blue cells for FAD indicate next higher standard line size recommended. Red value for BKW indicate suitable for Intermittent Duty Applications only & not fit for continuous 24/7 running.

PERFORMANCE TABLE HELI-HYBRID ROTARY BLOWERS

MODEL	AIR COOLED																		WATER COOLED OR SYNTHETIC OIL LUBRICATION			
	SPEED	1000 mmWC		2000 mmWC		3000 mmWC		4000 mmWC		5000 mmWC		6000 mmWC		7000 mmWC		8000 mmWC		9000 mmWC		10000 mmWC		
	RPM	m <sup>3</sup> /hr	BKW	m <sup>3</sup> /hr	BKW	m <sup>3</sup> /hr	BKW	m <sup>3</sup> /hr	BKW	m <sup>3</sup> /hr	BKW	m <sup>3</sup> /hr	BKW	m <sup>3</sup> /hr	BKW	m <sup>3</sup> /hr	BKW	m <sup>3</sup> /hr	BKW	m <sup>3</sup> /hr	BKW	
HHL300	800	5118	18.1	5019	32.7	4943	47.3	4879	61.8	4822	76.4	4771	90.9	4724	105.5	4680	120.0	4639	134.6	4600	149.2	
	1000	6457	22.7	6358	40.9	6282	59.1	6218	77.3	6162	95.5	6110	113.7	6063	131.9	6020	150.1	5979	168.3	5940	186.5	
	1200	7797	27.2	7698	49.0	7622	70.9	7557	92.7	7501	114.6	7450	136.4	7403	158.2	7359	180.1	7318	201.9	7279	223.7	
	1400	9136	31.7	9037	57.2	8961	82.7	8897	108.2	8840	133.6	8789	159.1	8742	184.6	8698	210.1	8657	235.6			
	1600	10476	36.3	10376	65.4	10300	94.5	10236	123.6	10180	152.7	10129	181.9	10082	211.0							
	1700	11145	38.5	11046	69.5	10970	100.4	10906	131.4	10849	162.3	10798	193.2	10751	224.2							
	1800	11815	40.8	11716	73.6	11640	106.3	11576	139.1	11519	171.8	11468	204.6	11421	237.3							
HHL350	600	8723	33.9	8,534	58.8	8,389	83.8	8267	108.7	8159	133.7	8062	158.6	7973	183.5	7889	208.5	7811	233.4	7737	258.4	
	700	10252	39.5	10064	68.6	9919	97.7	9797	126.8	9689	155.9	9592	185.0	9502	214.1	9419	243.2	9341	272.3	9267	301.4	
	800	11782	45.2	11593	78.4	11449	111.7	11327	145.0	11219	178.2	11122	211.5	11032	244.7	10949	278.0	10871	311.2	10797	344.5	
	900	13312	50.8	13123	88.2	12978	125.7	12856	163.1	12749	200.5	12651	237.9	12562	275.3	12479	312.7	12401	350.1	12327	387.5	
	1000	14842	56.5	14653	98.1	14508	139.6	14386	181.2	14278	222.8	14181	264.3	14092	305.9	14008	347.5	13930	389.0	13856	430.6	
	1100	16371	62.1	16183	107.9	16038	153.6	15916	199.3	15808	245.0	15711	290.8	15621	336.5	15538	382.2	15460	427.9	15386	473.7	
	1200	17901	67.8	17712	117.7	17568	167.5	17445	217.4	17338	267.3	17241	317.2	17151	367.1	17068	417.0	16990	466.8			

Blue cells for FAD indicate next higher standard line size recommended. Red value for BKW indicate suitable for Intermittent Duty Applications only & not fit for continuous 24/7 running.

DIMENSIONS AND WEIGHT TRI-LOBE

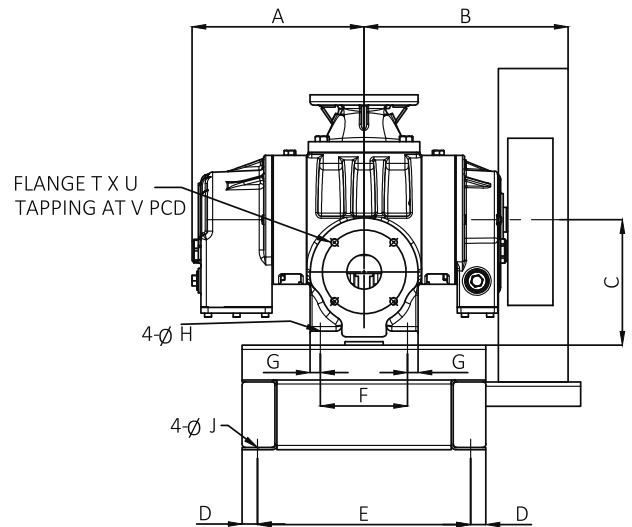
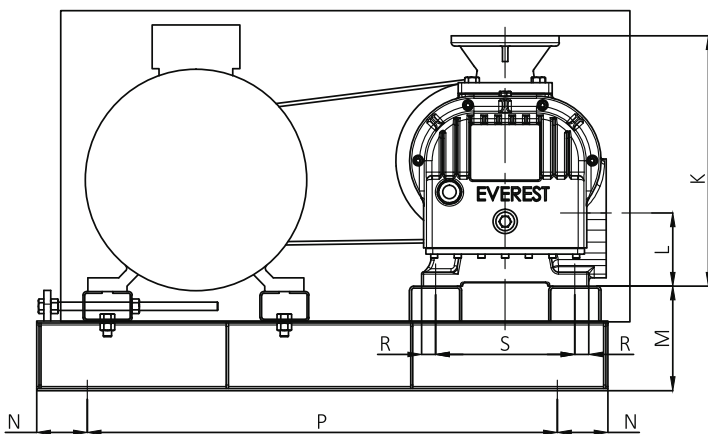

Model	A	B	C	D	E	F	G	H	J	K	L	M	N	P	R	S	T	U	V	WT. (KG)	Line size (NB)	Noise Level dB(A)	Orientation	Application
HHL65	290	340	180	22	306	200	20	15	12	360	105	150	73	675	20	200	4	M12	140	340	65/80	78	RAF	Air/Gas
HHL100	376	450	225	25	400	290	20	15	12	370	120	150	100	675	25	250	8	M16	180	440	100/125	83	RAF	Air/Gas
HHL150	489	566	310	33	635	424	24	19	15	515	155	200	200	900	25	350	8	M20	239	1090	150/200	90	RAF	Air/Gas
HHL200	501	570	363	33	635	270	35	23	15	651	190	200	235	1180	30	570	12	M20	299	2130	200/250	98	RAF	Air/Gas
HHL250	596	666	390	33	725	450	40	23	19	678	215	200	235	1180	30	570	12	M20	362	2380	250/300	100	RAF	Air/Gas
HHL275	677	865	495	33	635	450	45	27	19	858	240	200	250	1325	35	710	12	M20	406	3500	300/350	100	RAF	Air/Gas
HHL300	818	1030	490	33	1165	650	68	27	19	795	240	200	250	1325	35	710	12	M20	406	4130	300/350	101	RAF	Air/Gas
HHL350	965	1065	580	40	1400	836	82	30	24	1020	278	250	300	2000	45	830	14	M24	476	6000	400/450	102	RAF	Air/Gas

\* Max. height of blower (From hook top to foot bottom or Blower Discharge top to foot bottom) Units: mm, Weight (WT.) : Blower weight in "Kg"  
The above Noise Level are given considering Blower without Acoustic Hood at 1500 RPM and 4000 - 5000 mmWC

It's all about the...

# an Innovative Design

The Heli-Hybrid Blower utilizes the **extremely efficient** helix rotor design

## Why Heli-Hybrid ?

- Lower Noise
- Reduced Pulsations
- Higher Reliability
- Higher Efficiencies
- Lower Costs, Saves Money
- Reducing Enclosure & Hearing Protector Requirements

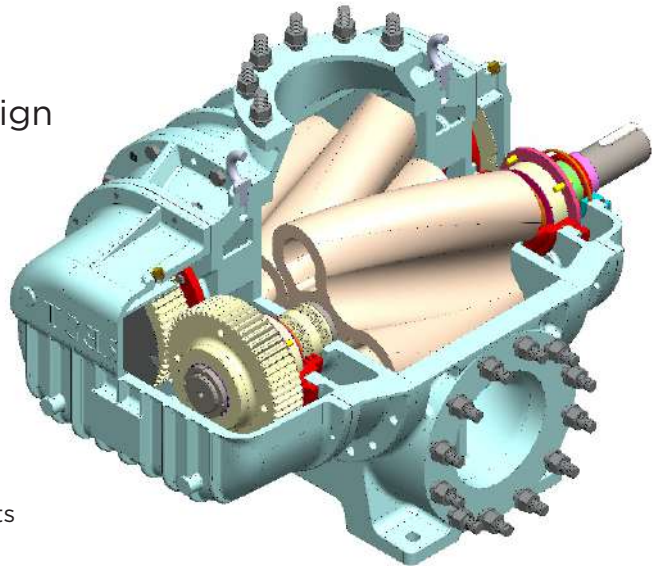

**Q** What is the difference between helical-type rotors and straight rotors?

**A** Everest helical rotors have three lobes twisted at an helix angle so that they displace the air continuously to prevent pulsating noise from occurring.

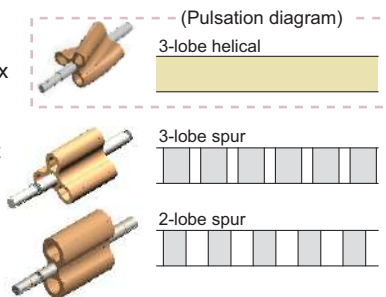

**Q** When the rotors are helical, does the amount of blown air drop for each rotation?

**A** The amount of air blown in helical type per rotation is more than straight type blowers as the slip is less than straight type lobe.

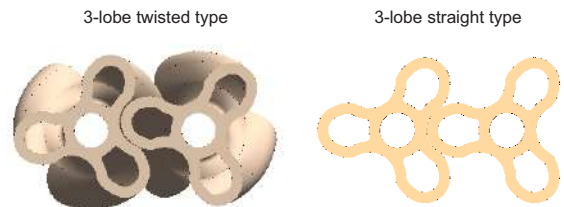

**Q** Because there is only a small gap between the helical rotors and the rotor housing, is high-precision machining required?

**A** A high-precision machine called a CNC 5 Axis machine with rotary table is used for machining the helical type rotor so that the rotors are manufactured with high precision and high reliability.



**Q** How do you inspect the twisting of the precision rotors and the curve of the teeth?

**A** The shape of the rotor profile is inspected using coordinate measuring machine (CMM). Measurement results are output to a plotter. Thorough quality control is carried out to ensure that the curvature of the lobe profile is within the allowable tolerances.



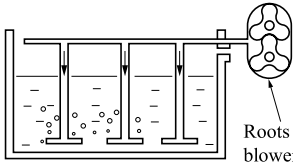
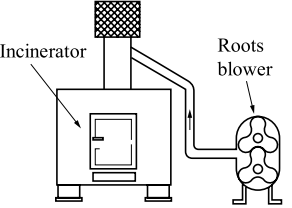
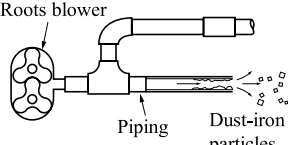
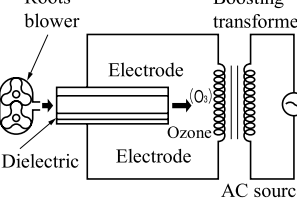
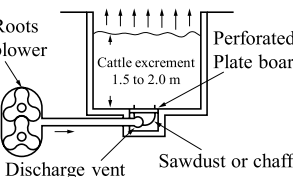
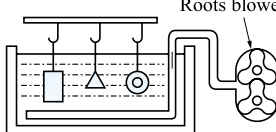
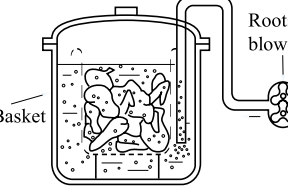
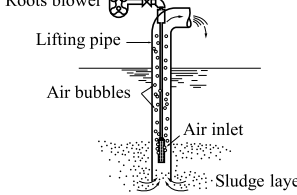
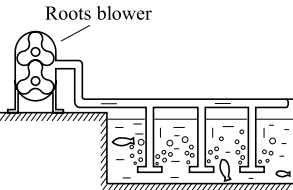
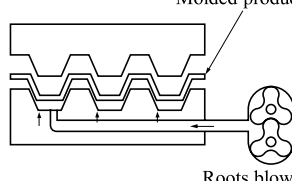
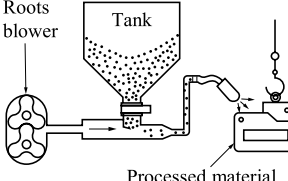
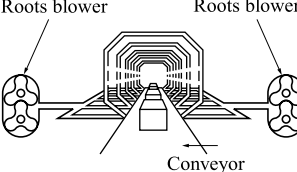
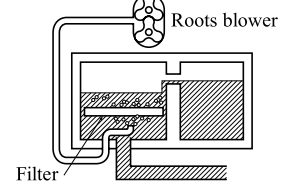
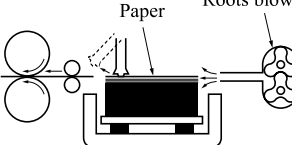
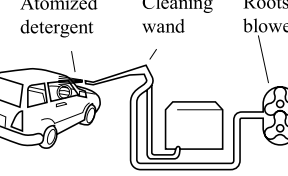
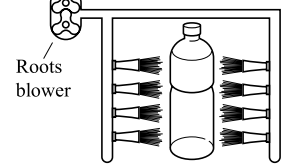
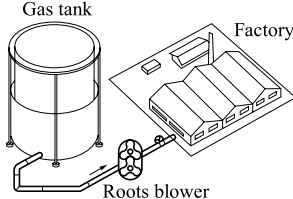
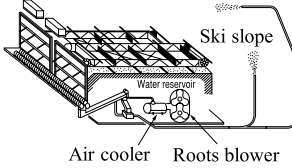
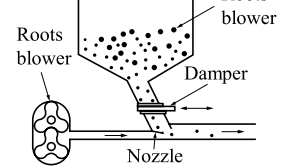
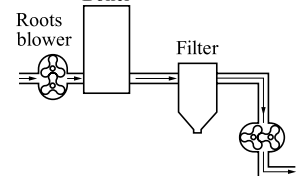

APPLICATION OF HELI-HYBRID SERIES

Water Treatment	Incinerators	Pipe Clearing	Ozone Implement
 <p>It is used for aeration and the stir in the water treatment plant.</p>	 <p>Blower enhances the combustion efficiency, and promotes the exhaust gas removal.</p>	 <p>Blower is used to clean of pipe and to supply the coating to piping.</p>	 <p>Blower is used as an air supply of the high concentration ozonizer.</p>
Compost Ferment	Plating Bath	Frozen Food	Airlift Pump
 <p>The air of blower promotes the fermentation of domestic animal's excreta etc.</p>	 <p>Plating quality can be enhanced by using a blower to circulate electrolytes in the plating bath to give the plating a more uniform thickness. Here blowers serve as the source of air supply.</p>	 <p>Blowers are useful in the freezing of frozen foods in water</p>	 <p>Bubbles formed by air jet lift water through the pipe by reducing the specific gravity of sewage.</p>
Pound Oxygen Providing	Press Machine	Sandblast	Produce Line Drying
 <p>Blower is used for the Oxygen supply of aquafarm, for the stir. Blower is used also in the aquarium etc.</p>	 <p>Blower is used for lift when removing molded products from the press.</p>	 <p>Provides a concentrated blast of air for use in sandblasting.</p>	 <p>Our blowers are used to good effect in small scale drying lines.</p>
Back Washing	Imprinter Paper Feeding	Atomization of Detergent	Air Blower
 <p>Blower is used to wash the filter etc by reversal flow.</p>	 <p>The exhalation air of blower helps the separation and distribution of paper.</p>	 <p>Blowers convey energy at car washes by atomizing water and detergent.</p>	 <p>Blowers are used to blow off drops of water clinging to surfaces of cans, bottle, machine part. Air blowers can also be used as sources of cooling or drying air.</p>
Special Gas	Snow Machine	Powder and Grain Transportation	Combustion Gas Recovery
 <p>Blower is used for the supply of the city gas etc.</p>	 <p>Blower is used for pneumatic transportation in the snow machine.</p>	 <p>Blower is used for the pneumatic transportation of the pellet of vinyl chloride and polyethylene etc.</p>	 <p>Also used in the desulfurization of high-temperature combustion gas and flue gas.</p>

The World of Compressed Air Industry  
Now Gets Simplified Solutions !!!!

Celebrating **40**  
Years

## WE ARE THE BIGGEST ROOTS BLOWER MANUFACTURERS IN INDIA

- **Leading By Innovation**
- **Technically Stronger**
- **Physically More Connected**
- **Ready to take INDIA Global**



## EVEREST BLOWERS PRIVATE LIMITED



**Corporate Office**  
+91 11 45457777



**Sales**  
enquiry@everestblowers.com

**Factory**  
+91 1276 241281, 241282

**Tech/Service Support**  
customercare@everestblowers.com  
service.ebpl@everestblowers.com



**Web**  
www.everestblowers.com



**Fax**  
+91 11 45457718



**Corporate Office**  
B-44, Mayapuri Industrial Area, Phase 1, New Delhi 110064, India

**Factory**  
Plot No. 82-83, Sector 16, HSIIDC, Bahadurgarh 124507, Haryana, India

Follow us



ISO 9001:2015 | ISO14001:2015 | OHSAS 18001:2007 Certified

More than 1,50,000 Everest Blowers are running in over 38 countries world wide.