



# EVEREST ROTARY BLOWER INSTRUCTION MANUAL

**INSTALLATION | OPERATION | MAINTENANCE**

**TWIN LOBE  
& TRI LOBE  
PD BLOWERS**



# INDEX

Contents	Pg. No.
To Get The Most From Your Everest Blower	2
Safety Precautions	3
Working Principle	4
Introduction - Your Key To Trouble Free Service	6
Equipment Check & Storage	7
Installation	8
Drive Installation	9
Recommended Layout For Multiple Blowers Installation	10
Auxiliary Equipment	11
Accessories Layout For Everest Blowers	14
Lubrication	15
Special Note for Water Cooled & Gas~Biogas Blowers	18
Spares & Consumables	18
Orientation of Blowers	19
Blower Startup Checklist	20
Trouble Shooting	21
Fault Chart	23
Everest Wants To Know What You Think - Feedback Form	24
Notes	27

**Exploring** Heights  
**Setting** Benchmarks  
**To Become** World Class



Roots Blowers | Mechanical Vacuum Boosters | Dry Screw Vacuum Pumps  
 Acoustic Hoods | Industrial Vacuum Systems

## TO GET THE MOST FROM YOUR “EVEREST” BLOWER

- 1.0 Make sure proper oil levels are maintained in the gear end and grease/oil in the drive end.
- 2.0 Check oil level and grease every 40 hours of operation. Loss of oil or grease should be replenished.
- 3.0 First oil change should be done within the first 100 operating hours and thereafter every 1000 hours or more often, if oil gets dirty.
- 4.0 Check belt tension every fortnight. Too tight belts would cause premature bearing failure while too loose belts would cause overheating of belts and pulleys.
- 5.0 Check regularly for any knocking or abnormal sound. High frequency sound indicates bearing trouble. Knocking sound indicates rotor timing upset. Contact “Everest” for necessary adjustments.
- 6.0 Clean air filter every fortnight by reverse airflow. Chocked filter would result in excessive power consumption and overheating of blower. Replace filter every three months or earlier.
- 7.0 Check and clean air silencer every month.



### CAUTION



- **Everest Blower is shipped without oil.**
- **Before operating, put the required amount of oil into the reservoirs as per instructions under lubrication.**
- **Do not fill oil reservoirs until blower is mounted in its operating location.**



### NOTICE



- **Everest Blowers are meant for indoor installation or should be protected from direct rain and sunlight, if installed outdoor.**

**SAFETY  
FIRST**THE SAFE WAY IS  
THE BEST WAY**SAFETY PRECAUTIONS****SAFETY  
FIRST**DON'T TAKE  
CHANCES

Safety is everybody's business and is based on your good use of common sense. All situations or circumstances cannot always be predicted and covered by established rules. Therefore, use your past experience, watch out safety hazards and be cautious. Some general safety precautions are given below.

**DANGER**

Failure to observe these notices could result in injury or death of personal.

- Keep fingers and clothing away from blower inlet and discharge ports, revolving belts, pulleys, drive coupling etc.
- Do not use the air discharged from this unit for breathing - not suitable for human consumption.
- Do not loosen or remove the oil fill plug, drain plug, covers or break any connections, etc., in the air or oil system until the unit is shut down and the air pressure has been relieved.
- Electric shock can and may be fatal.
- Open main, disconnect switch, tag and lockout before working on the control.
- Disconnect the Blower unit from its power source, tag and lockout before working on the unit.

**WARNING**

Failure to observe these notices could result in damage to equipment.

- Stop the unit if any repairs or adjustments on or around the Blower are required.
- Disconnect the Blower unit from its power source, tag and lockout before working on the unit.
- Do not operate unit if safety devices are not operating properly. Check periodically. Avoid bypassing safety devices.



## EVEREST TWIN LOBE ROTARY AIR BLOWER WORKING PRINCIPLE

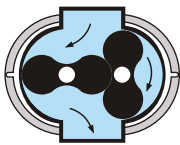

POSITION-1

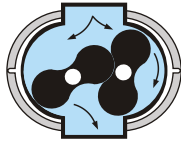

POSITION-2

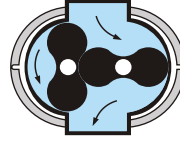

POSITION-3

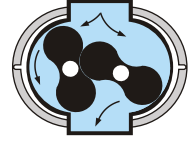

POSITION-4

Everest Twin Lobe Rotary Compressors/Blowers are positive displacement units, whose pumping capacity is determined by size, operating speed and pressure conditions. It employs two Twin Lobe impellers mounted on parallel shafts, rotating in opposite direction within a casing closed at the ends by side plates. As the impellers rotate, air is drawn into one side of the casing and forced out of the opposite side against the existing pressures. The differential pressure developed, therefore, depends upon the resistance of the connected system. The Blowers, being positive displacement type, do not develop pressure within the casing but the discharge pressure depends upon the system resistance / back pressure. Effective sealing of the compressor inlet area from the discharge area is accomplished by use of very small operational clearance, eliminating the need of any internal lubrication of the lobes. A pair of accurately machined alloy steel, hardened and ground timing gears maintain clearances between the impellers, during rotation. The air, thus delivered, is **100% OIL FREE**.

The pumping capacity of a lobe compressor, operating at constant speed remains relatively independent of inlet and discharge pressure variations. These Blowers are constant volume machines, which deliver a fixed discharge against the system back pressure. It is, therefore, essential to ensure that minimum pipeline restrictions, at the inlet and discharge, are imposed.

Adequate size piping and large radius bends ensure minimum line losses resulting in higher efficiency and low power consumption. Sudden change in pipeline cross section should also be avoided.

To change capacity, it is necessary either to change speed (energy saving) or vent some of the air into atmosphere (not energy saving). The air must not be recirculated from the discharge to suction as it may result in over heating. No attempt should ever be made to control the capacity of compressor by means of throttle valves in the intake or discharge piping. This increases the power load on the motor and may seriously damage the compressor. There is an increase in the discharge air temperature due to heat of compression. As a thumb rule the discharge air temperature increases @ 10°C for every 0.1 Kg/cm<sup>2</sup> of ΔP above the inlet temperature.

## EVEREST TRI LOBE ROTARY AIR BLOWER WORKING PRINCIPLE

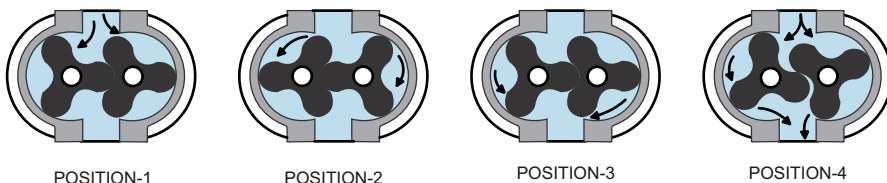

Everest Tri-lobe Rotary Compressors/Blowers are positive displacement units, whose pumping capacity is determined by size, operating speed and pressure conditions. It employs two Tri-lobe impellers mounted on parallel shafts, rotating in opposite direction within a casing closed at the ends by side plates. As the impellers rotate, air is drawn into one side of the casing and forced out of the opposite side against the existing pressures. The differential pressure developed, therefore, depends upon the resistance of the connected system. The Blowers, being positive displacement type, do not develop pressure within the casing but the discharge pressure depends upon the system resistance / back pressure. Effective sealing of the compressor inlet area from the discharge area is accomplished by use of very small operational clearance, eliminating the need of any internal lubrication of the lobes. A pair of accurately machined alloy steel, hardened and ground timing gears maintain clearances between the impellers, during rotation. The air, thus delivered, is **100% OIL FREE**.

The pumping capacity of a lobe compressor, operating at constant speed remains relatively independent of inlet and discharge pressure variations. These Blowers are constant volume machines, which deliver a fixed discharge against the system back pressure. It is, therefore, essential to ensure that minimum pipeline restrictions, at the inlet and discharge, are imposed.

Adequate size piping and large radius bends ensure minimum line losses resulting in higher efficiency and low power consumption. Sudden change in pipeline cross section should also be avoided.

To change capacity, it is necessary either to change speed (energy saving) or vent some of the air into atmosphere (not energy saving). The air must not be recirculated from the discharge to suction as it may result in over heating. No attempt should ever be made to control the capacity of compressor by means of throttle valves in the intake or discharge piping. This increases the power load on the motor and may seriously damage the compressor. There is an increase in the discharge air temperature due to heat of compression. As a thumb rule the discharge air temperature increases @ 10 °C for every 0.1 Kg/cm<sup>2</sup> of  $\Delta P$  above the inlet temperature.

## INTRODUCTION - YOUR KEY TO TROUBLE FREE SERVICE

Thank you for investing in Everest quality. The Everest reputation for rugged dependability has been earned by over 37 years of service in demanding, industrial operations where downtime cannot be tolerated and efficient blower performance is expected. Your Everest Blower is a precision-engineered blower that has been carefully manufactured and thoroughly tested at the state-of-the-art Everest Blowers factory.

As with other precision machinery, there are several relatively simple installation, operation and maintenance procedures that you must observe for optimum blower performance. There is no guesswork in the manufacture of your highly advanced Everest Blower and there must be none in preparing the Blower to get the job done in the field.

The purpose of this manual is to help you properly install, operate and maintain your Everest Blower. It is essential that you review all sections of this manual in preparation for installing your blower. Follow the instructions carefully and you will be rewarded with trouble free Everest service.....year in and year out.

### WHERE TO CALL FOR EVEREST BLOWER ASSISTANCE:

For prompt professional Everest service always contact your authorized Everest Distributor First. If you do not know your authorized Everest Distributor, contact the numbers below for immediate assistance.

### EVEREST CUSTOMER SERVICE / FACTORY SERVICE DEPARTMENT

**EVEREST BLOWERS PVT. LTD.**  
**B-44 MAYAPURI INDUSTRIAL AREA, PHASE - 1,**  
**NEW DELHI - 110064, INDIA.**  
**Ph : 91 - 11 - 45457740 | Fax: 91-11-45457718**  
**Email : [customercare@everestblowers.com](mailto:customercare@everestblowers.com)**

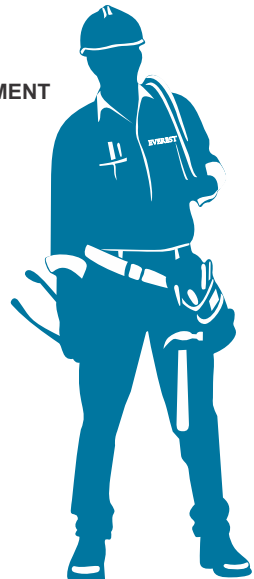

## EQUIPMENT CHECK & STORAGE

### EQUIPMENT CHECK:

On uncrating, check the packing slip carefully to be sure all the parts have been received. All accessories are listed as separate items on the packing slip, and small important accessories such as relief valves, can be overlooked or lost. After every item on the packing slip has been checked off, unpack carefully. Register a claim with the carrier for lost or damaged equipment.



### WARNING



**Customers are cautioned to provide adequate protection, warning and safety equipment necessary to protect personnel against hazards involved in installation and operation of this equipment in the system or facility.**

### STORAGE:

Your Everest Blower was packed at the factory with adequate protection to permit normal storage for upto three (3) months. If the unit is to be stored under adverse conditions or extended period of time, the following additional measures should be taken to prevent damage.

- 1 Store the Blower in a clean, dry area.
- 2 Make certain inlet and discharge air ports are tightly covered to prevent foreign material from entering the air box.
- 3 All exposed, non-painted surfaces should be protected against rust and corrosion.
- 4 Provide adequate protection to avoid accidental /mechanical damage.
- 5 In high humidity or corrosive environments, additional measures may be required to prevent rusting of the Blower internal surfaces.
- 6 To prevent rusting of gears, bearings etc., the oil reservoirs may be filled with normal operating oil.
- 7 Rotate the Blower shaft (10 to 25 turns) monthly during storage. Inspect the Blower shaft (near shaft seal area) monthly and spray with rust inhibitor if needed.
- 8 For long-term storage (over six (6) months) contact Everest Customer Care for recommendations.

### REMOVING PROTECTIVE MATERIALS:

The shaft extension is protected with rust inhibitor that can be removed with any standard solvent. Alternatively the Blower pulley is factory fitted on the shaft extension and it requires no cleaning.



Blower inlet & outlet are temporarily capped to keep out dirt and other contaminants during shipment. These covers must be removed before start-up. Keep them intact during the period of storage.

Everest Blowers are internally and externally treated to protect against normal atmospheric corrosion. Prior to installation remove covers from Blower inlet and discharge openings and inspect internals. If the cleaning is required, clean the internals thoroughly using any commercial solvent (e.g. Kerosene / Diesel). Continue this procedure until the unit is visibly clean. Check the drive shaft by rotating manually to ensure the impellers turn freely at all points. **No internal adjustment is generally required.**



### WARNING

Rotating components will cause severe injury in case of personal contact. Keep hands away from blower inlet and discharge ports.



## INSTALLATION

### LOCATION:

If possible, install the Blower in a well-lit, clean, dry place with plenty of room for inspection and maintenance. Protection from direct sunlight and rainwater is required. Effect of location on driver and accessory equipment must also be considered.

### FOUNDATIONS:

For permanent installations we recommend concrete foundations be provided, and the equipment must be leveled, free of all strains, and anchored so no movement will occur during setting of grout. After grout has completely hardened, a recheck is necessary to compensate for shrinkage etc. If required add shims under Blower feet before final tightening of foundation bolts to remove strain from the Blower housing. Blower assembly can be mounted on Anti Vibration Pads and directly placed on leveled concrete surface.



### WARNING

Handling of equipment needs to be accomplished with care, and in compliance with safe practices.



## DRIVE INSTALLATION

### DIRECT DRIVE (COUPLED):

On the direct connected units, alignment and lubrication of couplings to specifications of the coupling manufacturer is very important. When mounted drives are supplied from the factory, proper alignment has been established before shipment. However, during shipping, handling and installation, it is likely that the alignment has been disturbed and final adjustment must be made before start up. A flexible type coupling should always be used to connect the driver and blower shaft.



### WARNING

**Misalignment of coupling halves leads to unwarrantable premature bearing failure and shaft breakage.**



### BELT DRIVE:

Belt drives must be carefully aligned. Motor and blower pulleys must be parallel to each other and in the same plane. Belt tension should be carefully adjusted to the belt manufacturers recommendation using a belt tension gauge. Check tension frequently during the first day of operation.



### WARNING

**Over tightened belts lead to heavy bearing loads and shaft deflections and may result in premature failure of bearings / shafts.**



The location of pulley on the Blower shaft greatly affects the stress in the shaft. The optimum blower pulley positioning is as close as possible to the blower drive shaft bearing cover, to minimize overhung loads.

### PIPING:

Inlet and discharge connections on all blowers are large enough to handle maximum volumes with minimum friction loss. Reducing the pipe diameter on either inlet or discharge will only create additional line loss and increase the overall differential pressure and input power.

Pipe threads / flanges (suction and discharge) must meet the blower connections accurately and connections by springing or cramping the pipe or by forcefully connecting the two may result in distorting the blower casing and thereby causing serious damage to the Blower. For similar reasons, piping should be supported near the blower to eliminate dead weight strains on the blower. A flexible pipe bellow is recommended in the discharge pipeline, close to the blower discharge, so as to isolate blower and pipeline vibrations.

## DRIVE INSTALLATION

Avoid sharp bends in the suction and discharge line. Use adequate size pipe with large radius bends. This would keep pipeline pressure losses to bare minimum. As a thumb rule the line size should be such that the air velocity is in the range of 20-25 m/sec. Gate valves, nozzles etc. should be avoided, since they cause turbulence and have not much utility. If at all they must be used, ensure they are sized properly.



**WARNING**  
All system piping must be cleaned internally before connecting to the Blower



### MULTIPLE BLOWER INSTALLATIONS:

When two or more blower are connected to a system through a common header, the line sizes should be adequately designed to handle the flow rates. Generous line sizes would result in low line losses and consequently power saving. Refer to proposed layouts as shown below:

## RECOMMENDED LAYOUT FOR MULTIPLE BLOWERS INSTALLATION

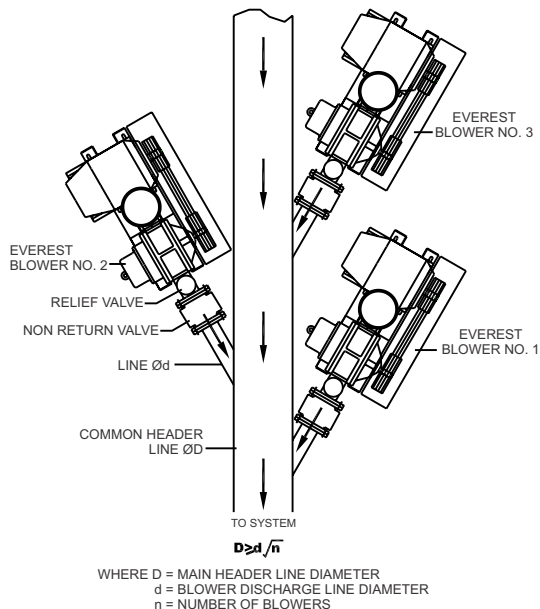

## AUXILIARY EQUIPMENT

The auxiliary items that might be required under various operating conditions are:

### SILENCERS:

The need for silencer depends on Blower speed and pressure as well as sound level requirements in the general surroundings. Silencers should be mounted as close to the blower as possible.

### SUCTION FILTER:

An inlet filter is generally recommended, especially in dusty locations, as it safeguards the machine against dirt and dust. The filter should be periodically checked for choking. Choking of filter would result in pressure drop across it thereby increasing the load on the Blower marked by increase in power intake. The filter element should be regularly cleaned by reverse jet of air. The pressure drop across the filter should not exceed 100mm WG. Replace filter every three months.

### WARNING



Choking of suction filter leads to increased load on the blower. Replace filter every three months. Servicing the air filter is one of the most important maintenance operations to be performed periodically to ensure long blower life.

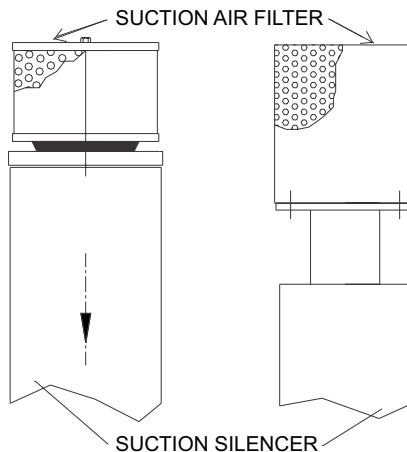

*Clean Air Filter every fortnight by reverse air flow. Choked filter would result in excessive power consumption and overheating of the blower. Replace filter every three months or earlier, if inspection so demands. Check and clean Air Silencer every month.*

## AUXILIARY EQUIPMENT

### PRESSURE RELIEF VALVE:

A pressure relief valve is necessary in the discharge pipe to protect against any overloading in the discharge line. In case of discharge line pressure exceeding the set limits, the valve cap pops up, discharging air into atmosphere.



### NOTICE

Relief valve should be placed as close as possible to the Blower discharge. They are not meant to discharge full capacity and therefore cannot be taken as safeguard against total blockage.



### SAFETY RELIEF VALVE

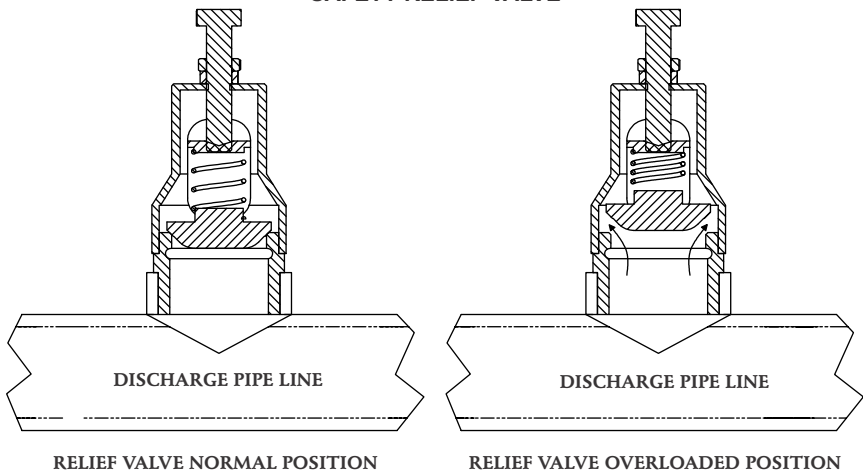

*Fig: Relief Valve Operation Illustration*

### NON RETURN VALVE (OPTIONAL):

Non-return valve may be fitted close to the discharge port to prevent the compressor from running in the reverse direction, when switched off under load conditions. In multiple blower installations when two or more units discharge into a common header, use of non return valves is recommended. One non-return valve should be located in each blower discharge line. Properly installed, they will protect against damage from reverse rotation caused by air back flow through an idle blower.

**MEASURING AND MONITORING DEVICES:**

Pressure gauge is supplied along with the supply and it is recommended to connect it to the discharge pipe line, close to the blower, to ensure that the system pressure is within the Blower rated pressure. However, U-Tube Mercury manometer may be used for more accurate observations. Special measuring and monitoring systems can be connected as per the individual requirement.

**CAPACITY CONTROL****CAPACITY CONTROL:**

The capacity of the blower can be varied by changing the blower speed, however, confirmation to the input power and maximum speed must be made prior to doing so. No valves should be put into the suction / discharge line to regulate the air capacity. One may, however, vary the discharge air capacity by venting out some of the air into atmosphere. Refer illustration below.

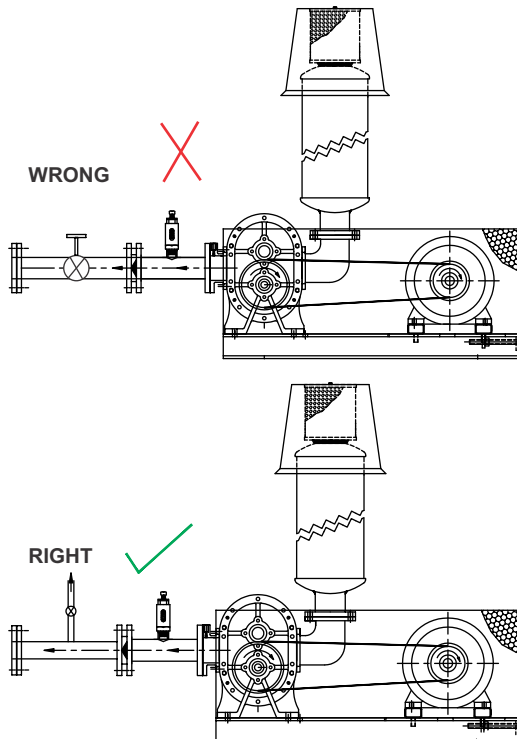

## ACCESSORIES LAYOUT FOR EVEREST BLOWERS

G.A. drawing for a typical Everest Blower. G.A. drawing of your particular Everest Blower was issued alongwith P.O. Acknowledgment, sectional drawing & bill of material. You may request for another copy of the same giving reference of P.O. No. & Date and Blower Model & Serial Number.

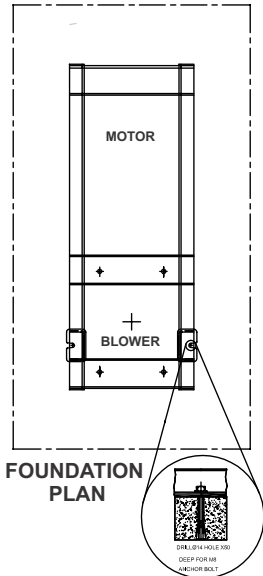

**Note:**

1. Direction Of Rotation Clockwise As Viewed.
2. Protect From Direct Sunlight & Rain.
3. Blower Opening Detail : 100 mm NB

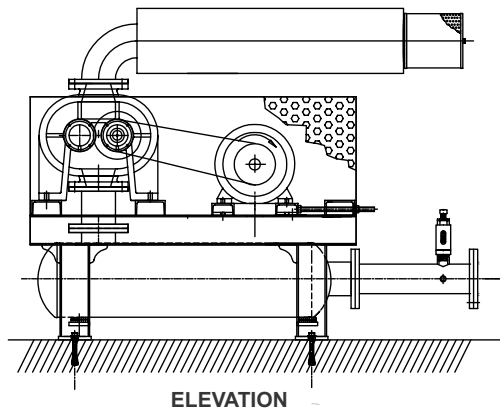
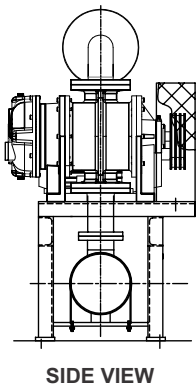
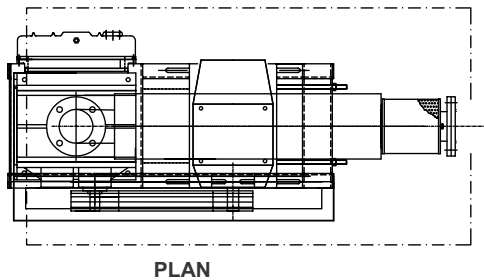

## LUBRICATION

EVEREST Twin Lobe Rotary Air Blowers have a very simple yet effective lubrication systems. At the gear end, the timing gear teeth are lubricated by being partially submerged in oil. A good grade industrial type, rust oxidation and foam inhibited, non-detergent gear oil (of medium viscosity) is recommended. The oil level indicator is provided at the back of the gear cover to monitor oil level. The oil should be periodically checked and fresh oil added as required to maintain proper level.



### WARNING

First oil change should be done within first 100 operating hours and thereafter, complete oil change is recommended after about 1000 operating hours or earlier if inspection so indicates.



During complete oil change old oil should be drained, gear cover flushed and then new oil added.



### WARNING

The recommended oil grade is Shell Spirax S2 G 90 / Indian Oil Servo Gear HP 90 / Castrol Hypoy EP 90 / HP Gear Oil EP 90 / MAK Spirol EP 90 / Indian Oil Servo Gear Super 90. Recommended grease grade is Castrol AP2 / AP3.



The Blower drive end bearings are OIL / GREASE Lubricated.

A weekly check for oil, under normal conditions, ensure longer blower life. Refer Lubrication diagram as shown below.

## LUBRICATION DIAGRAM

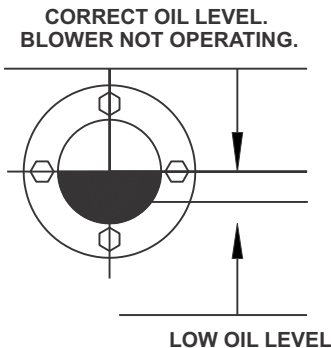



## LUBRICATION DIAGRAM

Lubrication points for different blower configurations.

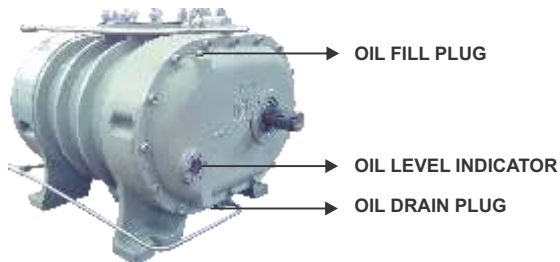
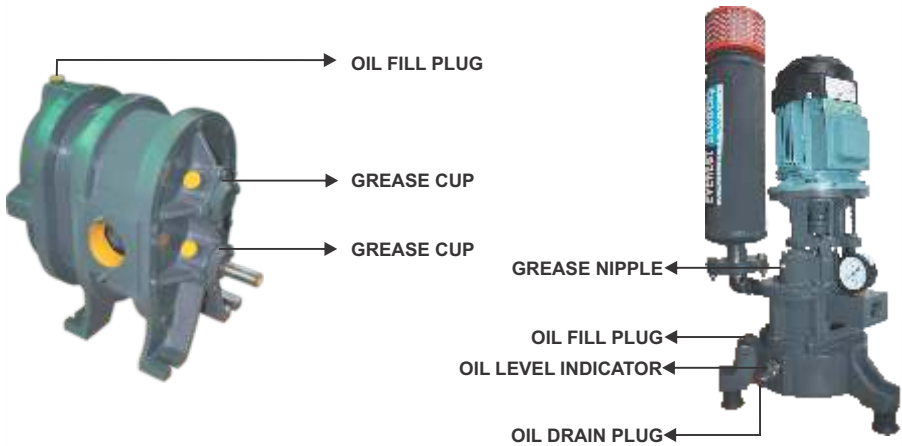
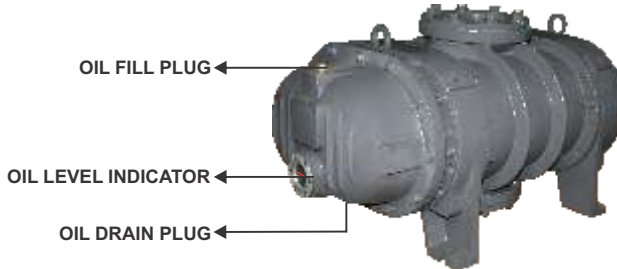

**WARNING**

**Do not overfill. This will cause excessive heating of the gears and may damage the unit.**



Correct lubrication is probably the most important requirement, other than operating the blower within its specific rating limits. In a blower there are no moving contacts between the two impellers or between impellers and the body or side plates. The wear is then, confined to the timing gears, the bearings and the shaft seals. All are lubricated and wear would be nominal if clean oil of proper grade is always used.

Timing gears wear should be negligible over the normal period of service. Gear teeth are hardened and ground to super finish. A reasonable degree of tooth wears, which normally can be accommodated without permitting contact between lobes.

However, high oil level in the gearbox would cause churning and excessive oil heating usually indicated by high temperature at the bottom of the sump. If operation is continued under this condition, gear will wear and tooth clearance will be lost. Rapid tooth wear will then probably develop, which will eventually produce impeller knocking. From this point serious damage will be unavoidable if operations are continued. Tooth fracture, brought on by sustained overloading and shock loads would produce similar results suddenly. Shaft bearings are critical in the service life of the Blower. Gradual wear may allow shaft position to change slightly until rubbing develops between impellers and casing or plates. Sudden bearing failure is usually more serious. Since the impellers shaft assembly is no longer supported and properly located, extensive damage is likely to occur if operation is continued. It has been observed that main cause of premature sudden bearing failure is either lack of lubrication or contamination. It is, therefore, strongly advised to take all the necessary steps to ensure proper, clean lubrication of gears and bearings.

**WARNING**

**Ensure Lubrication of Bearings and Gears is regularly maintained.  
This avoids premature failure of Blower.**



**Provide suitable protection / cover to prevent Lubricant getting  
contaminated by dust, dirt and water as these render it ineffective.**

## SPECIAL NOTE FOR WATER COOLED & GAS~BIOGAS BLOWERS

Pressure duty air blowers are not recommended for use in Gas~Biogas and Vacuum duty applications.

Water cooled blowers are similar to air cooled blowers except for the provision for cooling of end plates by water circulation in water cooled blowers. Water cooled blowers are recommended for applications where differential pressure ( $\Delta P$ ) across the blower is high or inlet gas temperature is high. The objective is to cool the lubricant & bearings and not the discharge gas.

Incase of Gas~Biogas blowers, vacuum switch may be provided at the inlet of the blower, so that incase the biogas generation falls below the pumping speed of the blower, the blower trips and this prevents vacuum overloading. Similarly, a pressure switch may be installed on the discharge line to safeguard the blower against excessive discharge pressures.

## SPARES & CONSUMABLES

**Recommended Spares:** Bearings, lip seals/labyrinth seals/piston rings, & gaskets.  
**Consumables** such as filters, vee-belts, lubricating oil & grease do not form a part of spares.

### Everest Spares and Consumables



BEARINGS



GEAR OIL

### SILENCERS & FILTERS



### VEE BELTS



### SEALS



## ORIENTATION OF BLOWERS

All blower models are available in specific orientations (based on direction of flow of air/gas). Broadly they may be Horizontal flow, Vertical flow or Right Angle Flow.

### HORIZONTAL FLOW ORIENTATION

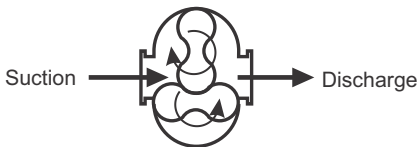

### VERTICAL FLOW ORIENTATION



### RIGHT ANGLE FLOW ORIENTATION

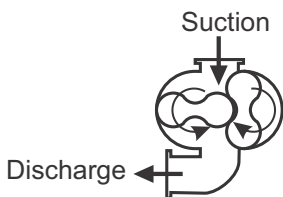

## BLOWER STARTUP CHECKLIST

This startup procedure should be followed during the initial installation and after any shutdown periods or after the blower has been worked on or moved to a new location. It is suggested that the steps be followed in sequence and checked off in the boxes provided.



- Check the unit and all piping for foreign materials and clean if required.
- Check the flatness of the feet and alignment of the drive. Feet that are bolted down in a bind can cause distortion of the casing, disturbing the internal clearances.
- If blowers are V belts driven, check the belt tension and alignment. Over-tensioned belts create heavy bearing loads, which leads to premature failure. Mis-aligned V belts can cause the impellers to rub against the side plates, resulting in overheating and jamming on operation. Misaligned couplings can cause premature bearings / shaft failures.
- Be sure adequate drive guards are in place to protect the operator from severe personal injury from incidental contact.
- Check the unit for proper lubrication. Proper oil level cannot be overemphasized. Too little oil will ruin bearings and gears. Too much oil will cause overheating and can ruin gears and cause other damage. Ensure both drive end & driven end are properly lubricated.
- With motor locked out, turn the drive shaft by hand to be certain that impellers do not bind.
- "Jog" the unit with the motor a few times to check direction of rotation and be certain it turns freely and smoothly.
- Start the unit and operate for 15 minutes at no load. During this time check for abnormal noise and other indications of interference.
- Apply the load and observe the unit for one hour. Check frequently for abnormal noise / over heating / overloading during the first day of operation. If malfunctions occur, do not continue to operate. Problems such as knocking impellers can cause serious damage if the unit is operated without correction.

Normal heating based on discharge pressure (as detailed in para 4 of “Working Principle” on page 4 & 5) is normal and no cause of alarm.



### NOTE ON INPUT POWER



The input power to the blower motor is proportional to the Blower speed and system back pressure. When operating at the rated speed, too high or too low power intake indicates change in differential pressure across the blower inlet and discharge port. During installation ensure the differential pressure does not exceed the rated pressure as increase in differential pressure would result in overheating / overloading of the blower. It is advised that when process has attained equilibrium the input power to the blower (or input current) may be recorded and change in this reading would indicate change in load conditions. Increase in power intake would result due to:

1. Suction filter getting choked
2. Suction / Discharge silencer getting choked
3. Suction / Discharge line valve, if any, not functioning / closed
4. Change in system parameters.

It is strongly recommended that the cause of overloading is rectified so as to prevent overloading & overheating of the blower.

## STARTING UP

After the final check-up the blower is ready for trouble free service.



### WARNING

Everest Blowers can generally be operated with direct starting motors against full pressure in the system. When using star-delta starting of motors or internal combustion engines, it may be required to start up in an unloaded condition.



## TROUBLE SHOOTING

Even though Everest Blowers are well designed and manufactured, there may be times when servicing will be required due to normal wear, the need for adjustment, or various external causes. In general, major repairs are to be considered beyond the scope of maintenance work and should be performed at the factory or by factory trained people.

The design of the blower is basically simple and many repair operations are straight forward but the work should be done by personal with good mechanical experience. Some operations involve extra care, patience and a degree of precision work. Well-qualified personnel, should only undertake adjustment and setting of internal clearances, as improper setting may cause serious damage to the blower.

Whenever the equipment needs attention, the operator or repairman should locate the cause and correct the trouble quickly. The trouble-shooting "Fault Chart" is provided to assist the mechanic in those respects.

FAULT CHART		
SYMPTOM	PROBABLE CAUSE	REMEDY
No air flow	<ul style="list-style-type: none"> <li>• Speed too low.</li> <li>• Wrong direction of rotation.</li> <li>• Obstruction in piping.</li> </ul>	<ul style="list-style-type: none"> <li>• Check speed and verify as per recommendations.</li> <li>• Check for correct direction of rotation.</li> <li>• Check suction and discharge line for any obstruction.</li> </ul>
Low capacity	<ul style="list-style-type: none"> <li>• Speed too low.</li> <li>• Excessive pressure.</li> <li>• Discharge line leaks.</li> </ul>	<ul style="list-style-type: none"> <li>• Check speed, belt drive slippage.</li> <li>• Check the line pressure.</li> <li>• Check up for open flow path.</li> </ul>
Excessive power consumption of blower	<ul style="list-style-type: none"> <li>• Speed too high.</li> <li>• Differential pressure across the suction and discharge openings too high.</li> <li>• Impellers rubbing.</li> </ul>	<ul style="list-style-type: none"> <li>• Correct the speed.</li> <li>• Check line pressure with rated pressure. Check &amp; Clean filter and silencer. Check for any obstruction in the suction and discharge line.</li> <li>• Check the impellers for any hot spots / rubbing marks. If observed, reset impeller timing. This operation requires skill and patience. if in doubt, contact "EVEREST".</li> </ul>
Overheating of bearings and gears / blower	<ul style="list-style-type: none"> <li>• Inadequate lubrication.</li> <li>• Differential pressure across the suction and discharge opening too high.</li> <li>• Coupling misalignment.</li> <li>• Belt slippage / Overtightened belts.</li> <li>• Too much oil in gear case.</li> <li>• Worn impeller, clearances too high.</li> <li>• Internal contact.</li> </ul>	<ul style="list-style-type: none"> <li>• Check for oil level and replace dirty oil.</li> <li>• Check line pressure with rated pressure. Check &amp; clean filter and silencer. Check for any obstruction in the suction and discharge line.</li> <li>• Check alignment and realign.</li> <li>• Adjust belt tension.</li> <li>• Correct oil level.</li> <li>• Replace impellers.</li> <li>• Reset clearances.</li> </ul>
Vibration	<ul style="list-style-type: none"> <li>• Drive misalignment.</li> <li>• Impeller rubbing (Distant knocking sound would be observed).</li> <li>• Worn bearings / gears.</li> <li>• Loose pulley / coupling.</li> </ul>	<ul style="list-style-type: none"> <li>• Check alignment.</li> <li>• Check for hot points. Recheck blower alignment and mounting, Recheck impeller timing.</li> <li>• Check and replace the bearings / gears.</li> <li>• Check if pulley / coupling is loose on shaft. Check key.</li> </ul>
Blower jams after running for a short period.	<ul style="list-style-type: none"> <li>• Insufficient axial clearances.</li> <li>• Differential pressure across suction &amp; discharge high, resulting in over heating &amp; subsequent jamming, due to thermal expansion.</li> </ul>	<ul style="list-style-type: none"> <li>• Correct clearances.</li> <li>• Correct differential pressures.</li> </ul>
Blower makes heavy knocking sound on running	<ul style="list-style-type: none"> <li>• Unit out of time.</li> <li>• Distortion due to improper mounting or pipe strains.</li> <li>• Differential pressure across the suction and discharge openings too high.</li> <li>• Worn bearings / gears.</li> </ul>	<ul style="list-style-type: none"> <li>• Retime impellers.</li> <li>• Check mounting alignment and relieve pipe strains.</li> <li>• Check gauge readings across the suction and discharge ends.</li> <li>• Check and replace the bearings / gears.</li> </ul>
Oil leaking out of oil fill hole	<ul style="list-style-type: none"> <li>• Excessive oil level.</li> <li>• Oil seal leakage.</li> </ul>	<ul style="list-style-type: none"> <li>• Correct oil level.</li> <li>• Check and replace oil seals.</li> </ul>
Traces of oil in blower casing	<ul style="list-style-type: none"> <li>• Oil seal leakage.</li> </ul>	<ul style="list-style-type: none"> <li>• Check and replace oil seals.</li> </ul>



Dearest Everest Customer,

Thank you for your purchase of Everest Products. To help us improve the products and services we provide you, please complete and return this questionnaire by fax / mail.

Fax : +91-11- 45457718  
 Email: [customercare@everestblowers.com](mailto:customercare@everestblowers.com)

## EVEREST WANTS TO KNOW WHAT YOU THINK

1. How did you first become aware of Everest's Products?
  - (a) Advertisement
  - (b) Colleague's Recommendation
  - (c) Internet
  - (d) Trade Show
  - (e) Others \_\_\_\_\_
2. What Industry are you in ? \_\_\_\_\_  
 \_\_\_\_\_
3. What convinced you to purchase Everest Products?
  - (a) Prior Experience using Everest Products
  - (b) Product quality
  - (c) Technical Support
  - (d) Knowledgeable sales people
  - (e) Service support
  - (f) Product Reliability
4. Please Indicate what Everest products do you use.  
 \_\_\_\_\_
5.
 

(a) Did you find it easy to place your order with us	Yes <input type="checkbox"/>	No <input type="checkbox"/>
(b) Did you receive your order on time?	Yes <input type="checkbox"/>	No <input type="checkbox"/>
(c) Is the shipment complete and free from damage?	Yes <input type="checkbox"/>	No <input type="checkbox"/>
(d) Are you satisfied with the workmanship?	Yes <input type="checkbox"/>	No <input type="checkbox"/>
(e) Is the documentation complete	Yes <input type="checkbox"/>	No <input type="checkbox"/>
(f) Is it performing to your expectations?	Yes <input type="checkbox"/>	No <input type="checkbox"/>
(g) Would you recommend Everest to others?	Yes <input type="checkbox"/>	No <input type="checkbox"/>
6. With respect to the above items, would you please indicate by its corresponding question number, in which areas can Everest most improve?

5 (a)     5 (b)     5 (c)     5 (d)     5 (e)     5 (f)     5 (g)

7. In order for us to maintain accurate records and minimize duplication of this questionnaire, we would appreciate if you will complete the following:

Name : \_\_\_\_\_

Company : \_\_\_\_\_

Designation : \_\_\_\_\_

Address : \_\_\_\_\_

City : \_\_\_\_\_

State : \_\_\_\_\_

Country : \_\_\_\_\_

Postal Code : \_\_\_\_\_

Phone : \_\_\_\_\_

Fax : \_\_\_\_\_

Email : \_\_\_\_\_

Website : \_\_\_\_\_

8. Comments : \_\_\_\_\_

\_\_\_\_\_

\_\_\_\_\_

\_\_\_\_\_

**Thank you for your time and input.**

**For internal use only:**

Received By :	Received on (Date):
Opportunity For Improvement / Complaint	
Signature (Service Head):	Signature (Unit Head):
Signature (COO):	Signature (Director):

Thank you for purchasing your equipments from Everest. In our pursuit of complete customer satisfaction we would appreciate your comments on the usefulness and readability of this manual. Please fax or mail this sheet to Everest Blowers Pvt. Ltd., B-44 Mayapuri Industrial Area, Phase -1, New Delhi - 110064, India. Kind Attention: Technical Publications Department. Our Fax Number is 91-11-45457718 & our email is [customercare@everestblowers.com](mailto:customercare@everestblowers.com). If we can be of any assistance to you, feel free to contact us at 91-11-45457777 Monday Thru Saturday, 9:00AM to 5:30 PM Indian standard time. Our weekly off day is Sunday.

Thanking you once again,  
 Manager  
 Technical Publications.

Everest Model No.

Everest Order No.

Revision Date of Manual \_\_\_\_\_

Please rate the following items :

- |   |                               |                               |                               |
|---|-------------------------------|-------------------------------|-------------------------------|
| Compared to similar manuals, this manual is ..... | Good <input type="checkbox"/> | Fair <input type="checkbox"/> | Poor <input type="checkbox"/> |
| Ease of reading is ....                           | Good <input type="checkbox"/> | Fair <input type="checkbox"/> | Poor <input type="checkbox"/> |
| Level of information is .....                     | Good <input type="checkbox"/> | Fair <input type="checkbox"/> | Poor <input type="checkbox"/> |
| Photographs and / or illustrations are            | Good <input type="checkbox"/> | Fair <input type="checkbox"/> | Poor <input type="checkbox"/> |
| The amount of information was.....                | Good <input type="checkbox"/> | Fair <input type="checkbox"/> | Poor <input type="checkbox"/> |

Comments:

\_\_\_\_\_

\_\_\_\_\_

\_\_\_\_\_

\_\_\_\_\_

\_\_\_\_\_

\_\_\_\_\_

\_\_\_\_\_

\_\_\_\_\_

**Please complete and return this questionnaire by fax / mail.**  
**Fax No : 91 - 11 45457718 | Email : [customercare@everestblowers.com](mailto:customercare@everestblowers.com)**  
**Your cooperation is greatly appreciated.**





## Customer Support

T: + 91 11 45457740 | E: [customercare@everestblowers.com](mailto:customercare@everestblowers.com)

### EVEREST PRODUCT RANGE



ROOTS BLOWER



MECHANICAL VACUUM  
BOOSTER

DRY SCREW VACUUM  
PUMP



ACOUSTIC HOOD



INDUSTRIAL VACUUM  
SYSTEM



We don't just offer **blowers, boosters and systems** we offer **solutions !!**







## Innovative Engineering Solutions

Our technology is so flexible, we can custom manufacture **Special Blowers, Vacuum Pumps & Systems** by alloying and cross linking diverse designs to suit individual requirements and import substitutes.



EVEREST PRODUCT RANGE Roots Blowers | Mechanical Vacuum Boosters | Dry Screw Vacuum Pumps | Acoustic Hoods | Industrial Vacuum Systems

Corporate Office: B-44, Mayapuri Industrial Area, Phase1, New Delhi 110 064, India | T: +91 11 4545 7777 | E: [enquiry@everestblowers.com](mailto:enquiry@everestblowers.com)  
Group Companies: Everest Blowers Pvt. Ltd. | Everest Blower Systems Pvt. Ltd.     [www.everestblowers.com](http://www.everestblowers.com)