

# ENHANCE THE PERFORMANCE OF LIQUID RING PUMPS USING EVEREST MECHANICAL VACUUM BOOSTERS

**Liquid Ring Pumps** are used throughout process industry. These pumps provide legitimate alternative to steam jet ejectors in applications requiring rugged pump that can tolerate entrained liquids, vapors and fine solids. These Pumps operate in a liquid environment, generally water and are capable of handling vapors along with non-condensable loads. They are extensively used in industrial processes such as filtration, drying, solvent recovery, distillation etc.

Unfortunately they suffer from two major limitations that restrict the process performance. They are:

- The final vacuum achievable, as it is largely dependent on the vapor pressure of the pump fluid corresponding to the working temperatures. For example, for water sealed pump, the lowest practical operating pressure for two-stage design would be in the range of 40 – 60 Torr (720-700mm Hg) for exit water temperature at 30-32 Deg. C.
- Their energy consumption per unit of gas pumped is higher since most of it is lost in handling pump fluid.

**Mechanical vacuum boosters (MVB)** overcome these limitations of **liquid ring pump (LRP)**. A properly matched MVB – LRP Combinations can result in:

- Higher working vacuums – any where the range of 50 Torr – 1 Torr (710-760mmHg) or better is achievable.
- Very high pumping speeds – generally to the order of 4-8 times higher.
- Vapor/gas compression at the inlet of the water ring pump allowing use of higher water temperature in the pump.
- Relatively very low energy consumption per unit of pumping speed.

Figure1 gives typical two stage WRP speed curve. The pumping speed is equal to the rated speed (displacement) during initial pumping and thereafter drops rapidly reaching to zero at its ultimate (690 – 720 mm Hg). In most of the chemical processes the process vacuum is in the range of 680-700mmHg where

the pumping speed of WRP is merely 15-20% of it's full rated capacity. This demands installation of much larger WRP loosing on one time pump cost and recurring energy charges. The power consumption, however, is largely constant throughout the range that makes LRP relatively less energy efficient in comparison to MVB-LRP Combination.

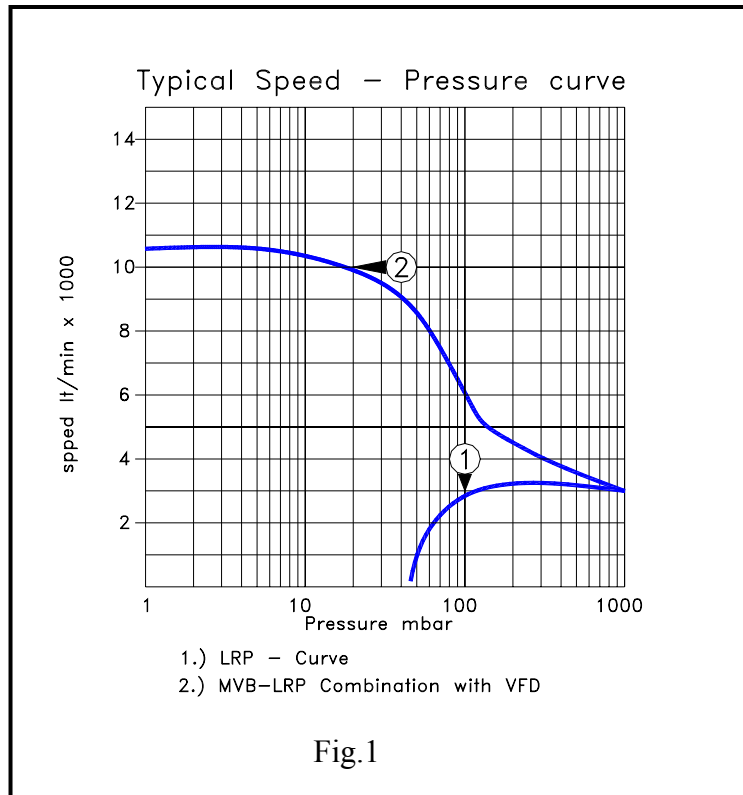

Fig.1

Curve2, Fig.1 gives a typical MVB-LRP (water-two stage) speed curve. As the WRP vacuum drops to the range of 60-100 Torr (660-700mm Hg), the Mechanical Booster boosts the effective speed manifold. As can be seen from the curve the booster exhibits relatively flat pumping speed curve in the region 10-1 Torr (750 – 760mm Hg), high pumping speeds and better process vacuum is achieved, overcoming the limitations of LRP in this range. The power consumption of the Mechanical Vacuum Booster is relatively low in this range as compared to any other conventional vacuum pump. Therefore, with little extra energy, the overall pumping speed and ultimate vacuums can be greatly enhanced. In many applications, replacing WRP with a smaller one can easily offset the extra energy of MVB.

Installation of MVB undoubtedly results in high pumping speeds and better vacuums. However, to get the best results in process its location is important. It can be effectively located between the condenser (**Post-condenser installation**) and the WRP or between the kettle/evaporator and the condenser followed by WRP (**Pre-condenser installation**). To enable to determine most effective location process parameters play an important role.

## POST CONDENSER INSTALLATION

Processes such as distillation of high boilers (kettle temp. are generally above 125°C), processes using chilled water condenser, processes having direct discharge of vapors to WRP, processes demanding vacuum close to condensate vapor pressure are generally the applications where post-condenser installations can give boost to the process, resulting in higher yields, lower process time and better product quality.

### TYPICAL POST CONDENSER INSTALLATION

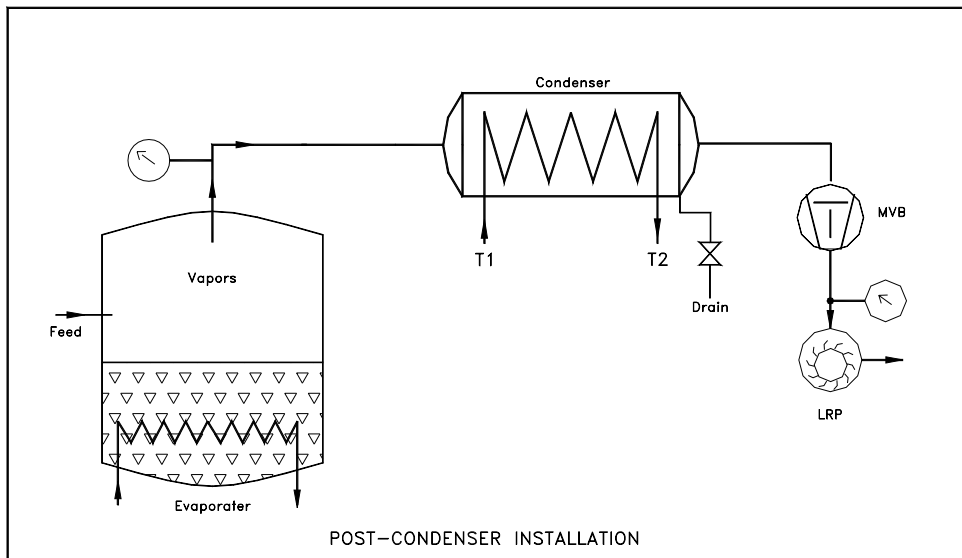

In drying applications where water vapor is exhausted from the dryer and cooling water of 10°C or lower is available in the condenser, post condenser installation would be a good choice. Since the vapor pressure of condensate (Water) at 10°C is about 9 Torr, (refer graph below) the condenser working vacuum can be estimated to about 20 Torr. Double stage WRP having fluid temperature in the range of 30-35°C would not be able to deliver working vacuum below 50-60 Torr (710-700 mm Hg). However on installation of Mechanical Booster between the

condenser and the WRP would very conveniently pull down vacuum to the range of 15-20 Torr (745-740 mm Hg). Still better vacuums can be possible if the condenser & condensate temperatures are lowered further.

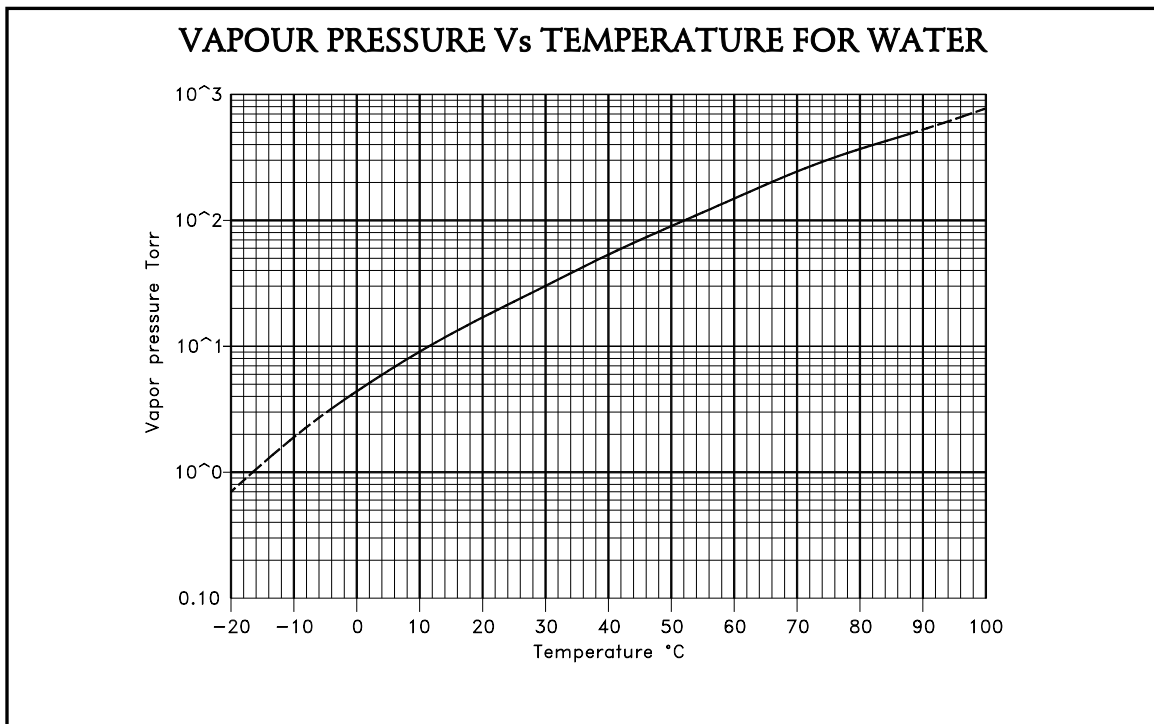

Another practical application of Post condenser installation is Menthol Distillation. The distillation process earlier was conducted under vacuum in the range of 690 –710mm Hg (70-50 Torr) with kettle temperatures in the range of 125 – 130°C.

On installation of MVB, the process vacuum reduced and lower temperatures of the range 95-105°C could be maintained resulting in better product quality and higher yields.

In some applications of drying/purification, it is more important to exhaust solvent to very low levels, typically less than 1%. At that levels (generally <1%) recovery and collection of solvent may not be very critical but product purity is of vital importance. In such applications post booster installations prove very effective. Initially when the solvent percentages are high MVB can be by-passed and most of the solvent can easily be recovered in the condenser. As the concentration of the mixture improves, leaving low percentage of solvent, need for finer vacuums and higher temperatures are felt. At this stage the condensate can be drained out-from the condenser and MVB started give high pumping speeds and finer vacuum. This would greatly enhance evaporation of solvent, giving high product purity. MVB performance is not effected by vapors as it can pump both condensable & non-condensable with equal ease. The above is possible in Batch processes only and for continuous process alternative arrangements can be adopted.

## **PRECONDENSER INSTALLATION**

For applications such as solvent recovery, low temperature drying, process where condenser temperature cannot be maintained low are some of the cases where pre-condenser booster installation would give very encouraging results. In Pre Condenser installation the MVB is installed between the evaporator and the condenser and handles the entire process vapors.



## TYPICAL PRECONDENSER INSTALLATION

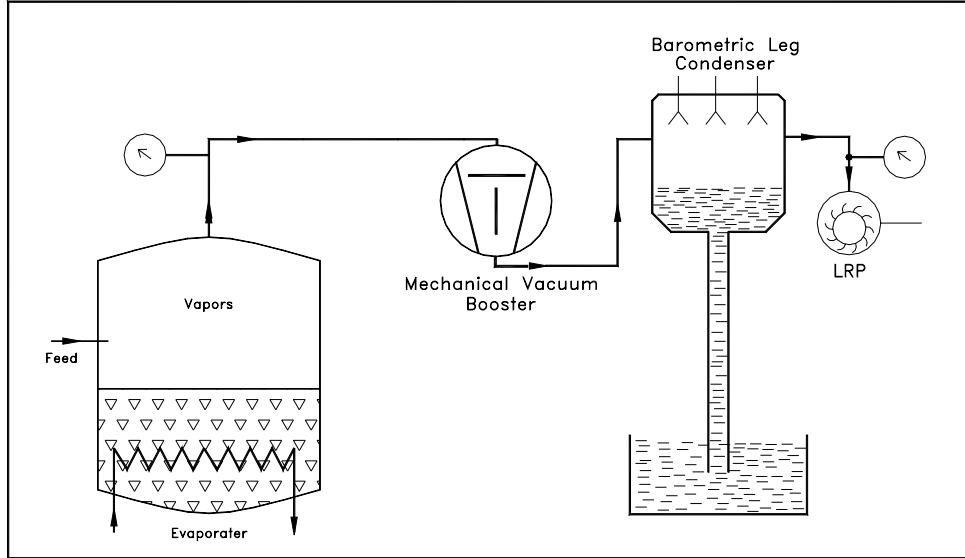

Principally condensation is just reverse of evaporation and therefore process parameters favorable for evaporation are generally not favorable for condensation and accordingly process parameters favorable for evaporation are not favorable for condensation. In most of the processes, vacuum system is installed in the fag end resulting in the entire process being under similar levels of vacuum. Thus a compromise is made regarding the system vacuum to get optimum results that generally are not the best, leading to high process time and compromise on product purity. Installation of MVB between the evaporator and condenser over comes the above limitations by creating high vacuum conditions at the evaporator and relatively high pressure conditions at the condenser, both of which tend to create ideal conditions in the evaporator and condenser for maximum efficiency. This would accelerate evaporation and at the same time allow full condensation in the condenser. Due to lower vacuums in the evaporator, lower evaporator temperature and better product purity can easily be achieved in a much shorter time. Similarly due to higher pressure at the condenser advantages such as higher rate of condensation, less sensitive to condenser temperature and lower load on the back up vacuum pump can be expected. Thus, it is obvious that MVB can create favorable conditions both for evaporator and condenser, which over wise may not be possible, resulting in better yield, better product quality and better recovery of condensate.

MVB are, therefore, an ideal choice for all major vacuum processes and their installation would definitely result in shorter process times and better product quality. Since various factors influences a process, proper selection and installation of MVB can yield good results in most of the cases.

MVB are very versatile machines with a wide range of operating vacuums, 100-0.001 Torr, depending on the selection of Backup pump. They can be used with LRP, Water ejectors, Steam Ejectors, Piston pumps and Oil sealed rotary pumps. The selection of the backup pump is based on the process requirements, pumping speeds desired and operating vacuum requirement.

Power Constraints restrict the total differential pressures across the booster. This demands to ensure the total differential pressure across the Booster must not exceed the rated limits. This can be ensured by any of the following means:

**MANUAL METHOD:** Initially the fore pump is switched on until the required cut in pressure is achieved and thereafter the booster is switched on.

**AUTO METHOD:** Installation of mechanical By-pass arrangement across the booster or hydro kinematic drive or Variable Frequency Drive (VFD). In this arrangement, the booster and fore pump can be started simultaneously from atmosphere. **VFD's** are most preferred devices used to regulate the Booster speed to match the varying load conditions of the process. These drives enhance the overall performance of the Boosters and offer various advantages for the trouble free operation.

The major advantages are: -

- Booster can be started directly from atmosphere.
- No need for separate pressure switch, by pass line or offloading valves
- Considerable savings in power.
- Prevents over-heating of Boosters.
- Protects the Booster against overload and excessive pressures.
- Offers complete protection to motor against over voltage, under voltage, over current, over-heating, ground fault.
- Eliminates the needs of separate starter and overload relays for the Motor.
- Automatically adjusts the speed of Booster between low and high range set giving high pumping speeds with relatively low input power.

VFD is a microprocessor based electronic drive that is specially programmed to meet the demands of the Booster allowing it to operate directly from atmosphere along with suitable back-up pump. Conventionally, Boosters can be started only after achieving fore vacuum in the range of 30 – 100 Torr, as they are not recommended for direct discharge into the atmosphere. Use of Pressure Switch, Hydro kinematic drive and by pass valves is necessary to prevent the overloading of the Booster. However with the installation of VFD all the conventional methods can be bypassed since the drive is programmed to regulate the Booster speed automatically, keeping the load on motor within permissible limits. This allows the Booster to start simultaneously with backup pump.



When the backup-pump and Booster are started the drive regulates the Booster speed low levels and as the vacuum is achieved the Booster speed picks up, reaching the final pre-set speed, giving most optimum performance over the entire range. Since all the parameters are easily programmable, one can adjust the booster pumping speeds to match the system requirements easily and quickly. The drive limits the current to the motor and safeguards the motor against over voltage, under voltage, electronic thermal, overheat ground fault.... i.e. protects the motor against all possible faults.

*Article compiled by technical team of Everest Transmission – The only successful manufacturer of Mechanical Vacuum Boosters in India.*

## **EVEREST TRANSMISSION**

B-44, Mayapuri Industrial Area, Phase-1, New Delhi-110064, India.

Telefax: 91-11-28114944, 28114955, 28116307, 28117469

Email: [info@everestblowers.com](mailto:info@everestblowers.com) Web: [www.everestblowers.com](http://www.everestblowers.com)