

## **FIRST EVER LOW TEMPERATURE THERMAL DESALINATION PLANT FOR PRODUCING POTABLE WATER BY INDIAN SCIENTISTS**



**Fig 1: Sea Water at Kavaratti (Lakshadweep)**

Fresh water is an essential requirement of mankind for drinking, agriculture & Industrial purpose & is amongst one of the most important input for man's survival. The rapid increase of world's population and non uniform distribution of potable water has forced mankind to develop new techniques to generate potable water. Fresh water rivers, lakes & other natural sources are not able to meet the over growing demand of potable water forcing the scientists to look towards the sea to fulfill the need of fresh water.

Sea water is available in abundance; however, its conversion to fresh water is limited & restricted due to high cost of conversion. The salt content in the sea water is very high making it unfit for human consumption and industrial use. Various processes are being developed to reduce the salinity of sea water so as to make it fit for human consumption and use. The most popular processes presently being used are Distillation, Reverse Osmosis & Electro dialysis. The selection of the right process depends upon the initial capital investment, plant capital, operation and maintenance costs etc. Scientists all over the world are constantly working on developing economical process so as to generate fresh water on large and economical sales.

**In this article the focus is primarily on the new process developed by Indian Scientists known as the process of "Low Temperature Thermal Desalination" (LTTD).**

0.1 Million Litres per day pilot plant on LTTD process has already been commissioned and is in operation since May 2005 which was designed, fabricated & installed by Indian Scientists at Kavaratti in Lakshadweep. The plant has been working since then, generating fresh water from the sea water to meet the drinking water needs of people of Kavaritti Island, part of Lakshadweep.

Sea water contains dissolved salts having a concentration of about 35,000 ppm which is too high for use by human beings. This level must be reduced below 500 ppm before it can be used. Distillation is the oldest and the most commonly used method of

desalination, where sea water is evaporated and vapours then condensed giving clean water. The latent heat of water is about 540 kcal/kg making the process highly energy intensive and conventional distillation columns prove uneconomical for production due to high input energy requirements. Various techniques are being used to recover the latent heat like multi effect evaporators, which can lower the energy requirement costs drastically. In LTTD method the energy requirement for the evaporation of water are taken from sea which makes the process eco-friendly and uses renewable source of energy.

**LTTD uses the temp difference which exists between the surface layer water (28°-30°C) & deep sea layer water (7°-10°C) existing in an ocean to produce potable water.**

The picture below (Figure 2) gives the Plant layout of LTTD installed at Kavaratti:

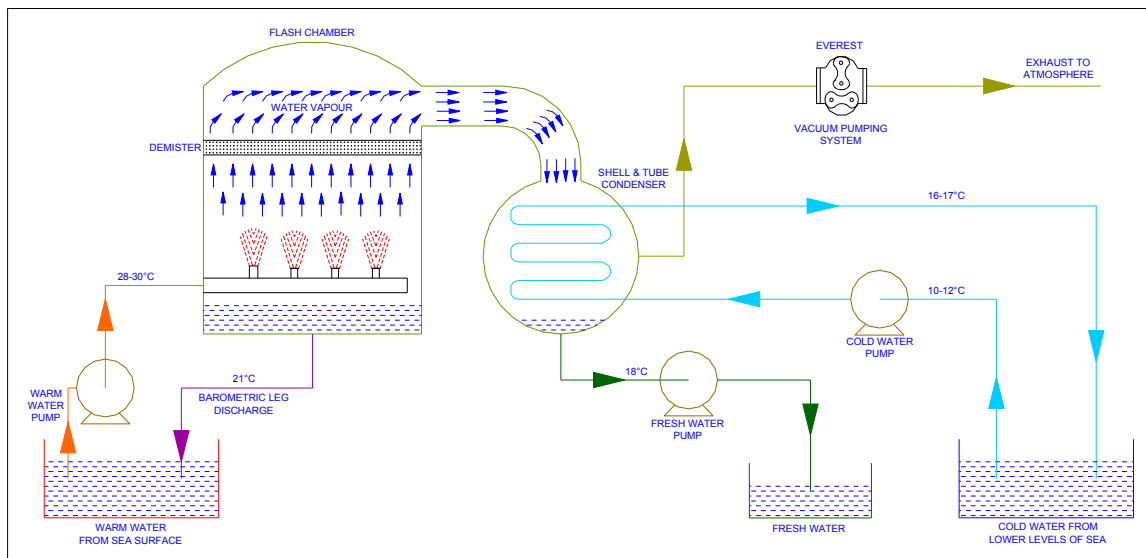

**Fig 2: Plant Layout for Low Temperature Thermal Desalination Plant**

The basic principle of Low Temperature Thermal Desalination Plant is as under:

The surface sea water at about 28°C – 30°C is pumped into flash chamber which is maintained under low pressure of about 25 mbar absolute (below the saturated vapour pressure of water). The warm sea water in the flash chamber evaporates due to low pressure being maintained, taking latent heat of evaporation from the warm water stream itself. The evaporated water vapours move towards the shell & tube condenser and the return water, losing temp by about 7°C is returned back to the sea. The main condenser has a circulation of cold sea water at a temp of 12°-13°C, pumped from the lower layers of sea & is used for the condensation of the evaporated water vapour. The condensate thus produced is fresh drinking water fit for human consumption. The cold water

pumped used in the condenser can subsequently be used for air conditioning as the return temperature of this water is around 17°-18°C. This water being pumped from the lower levels of the sea is rich in minerals & plankton and when discharged on sea surface becomes a potential breeding area for fish and other marine life.



**Fig 3 & 4: Everest Vacuum System for LTTD installed at Kavaratti (Lakshadweep)**



**Fig 5 & 6: Everest's Technical Team in close interaction with Indian Scientists at LTTD Plant in Kavaratti (Lakshadweep)**

LTTD method of producing fresh water from sea water consists of flash evaporator, main condenser, fresh water & warm water pump and a vacuum pumping system. Since the major equipment is static the entire project requires low maintenance, having long operational life (Refer schematic diagram). The surface sea water is pumped into the

flash chamber where low pressure is maintained. Almost 1% of water is evaporated in the flash chamber and the rest of the water freely flows back into the sea as the flash chamber is maintained at a barometric height. The vapours evaporated in the flash chamber are driven over the main shell & tube condenser and almost all of them are condensed. The cold source of water pumped from lower layers of the sea takes away the condenser heat. The discharge water of the condenser, available at about 17°-18°C, can be used for other cooling applications such as air conditioning etc before discharging back into the sea. During the process of evaporation non condensable gases released from the sea water & the plant leakage load are constantly pumped by a vacuum system to ensure that absolute pressure in the range of 25 mbar is maintained in the vessel. The estimated consumption of energy per KL on a medium size plant is estimated around 8 units/Kl of fresh water generated. As per the current rate of energy, the estimated cost of generation is about 3 paise/lit which is very economical as compared to other conventional methods presently in use. The main features of LTTD plant are:

- No pretreatment of feed water required.
- Assured consistent quality water fit for drinking as per WHO standards.
- Operational simplicity and easy maintenance.
- Zero environmental Pollution.
- Use of renewable energy.
- Highly nutrient cold water available which can be used to enhance marine life.



**Fig 7 & 8: Actual Site Photographs of LTTD Plant installed at Kavaratti (Lakshadweep)**

**Everest** has been proud to be associated with this project. Vacuum experts at Everest have designed and manufactured complete vacuum system capable of handling total non condensable & carry over water vapour load maintaining system pressure of 25 mbar. Everest .....leaders in Vacuum technology and manufacturers of Dry Mechanical Vacuum Boosters once again proved their capability to design, manufacture and deliver a vacuum system to meet the stringent needs of Indian scientists. We wish to thank our scientists for putting into actual use of concept, known for a long time but never attempted before.



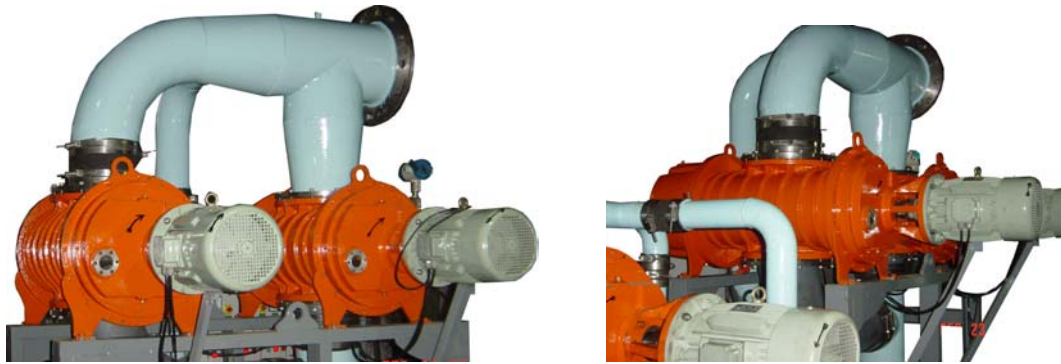

**Fig 9 & 10: Everest Vacuum Boosters installed in 1 MLD LTTD Plant in coastal waters of Chennai, Tamil Nadu.**

A 10 times larger project of 1.0 Million Litres per day (10 MLD) based on the above LTTD concept is already in advanced stage of erection & commissioning in the coastal waters of T.N. Here, Everest has once again extended its expertise & has undertaken the complete design, manufacture & supply of the vacuum system. To improve, additional technique of de-aeration of sea water prior to its admittance in the flash chamber is planned which should result in higher efficiency, yield and low power consumption. All the Vacuum pumping system for de-aerator has also been designed and supplied by Everest. 1 MLD project based on LTTD technique is in the advance stage of erection & commissioning and hope by the time the article is published, final trials would be through.

The above technology can extensively be used in many chemicals plants for treatment of effluent. In fact a project on similar lines is already in commissioning stage for concentration of Sodium Chloride solution in one of the large pesticide manufacturing units in India. The technical team at Everest, after being exposed to revolutionary technique of LTTD, gained valuable information and practical experience which has been put into commercial use by chemical and pharmaceutical Industry to economize production.

**Article compiled by technical team of:**

## **EVEREST TRANSMISSION**

**B-44, Mayapuri Industrial Area, Phase-1, New Delhi-110064, India.  
Web: [www.everestblowers.com](http://www.everestblowers.com) Email: [info@everestblowers.com](mailto:info@everestblowers.com)**

**EVEREST.....Leaders in Vacuum Technology**