

ROOTS BLOWERS

TECHNICAL BULLETIN 2004-1

EVEREST

FIELD SERVICE TROUBLE SHOOTING MANUAL

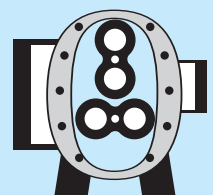
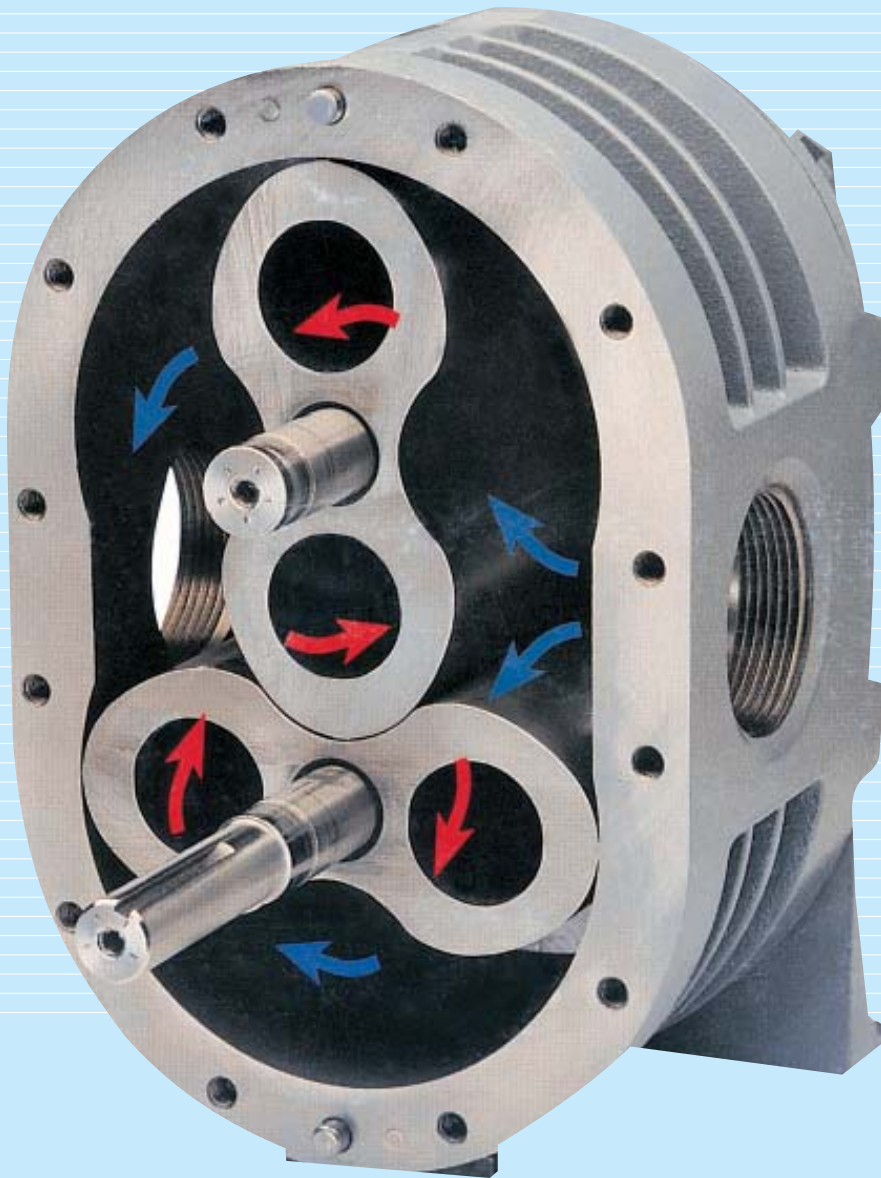

EVEREST Transmission



Blowers and vacuum boosters fail for a reason. The most common causes of failure include operating beyond the unit's limits of speed, pressure, compression ratios, temperature and horsepower. Additional failure causes are from installation mistakes, and the breakdown of lubrication, improper oils, and high operating temperatures. Process conditions that either deposit material inside the blower or corrode or erode the internal parts, mechanical damage due to foreign objects (weld slag, nuts, or bolts) or non-compressibles going through the blower (sludge or a slug of water), are not uncommon causes of failure.

When a unit fails, the cause of failure can normally be determined by inspection of the parts. The following are some things you can look for to help solve problems in the field.

OVERPRESSURE

There will be metal-to-metal contact between the non-drive end of the rotors and the endplate and/or between the rotor tips and the inlet side of the housing. The extent of contact is relative to the amount of overpressure. Extreme overpressure, a dead head (blocked discharge) or continued operation with contact occurring will cause the rotors to make contact with the gear end plate. Overpressure causes the discharge temperature to exceed operating limits. The heat expansion of the rotors is at a faster rate than the housing. This causes the rapid expansion of the rotors to use up the free-end clearances.

The process is the same for the rotor tips. The cool inlet side of the housing does not expand as quickly as the rotors causing loss of clearances and ultimately Blower seizing.

CAUSES

Everest Blowers being Positive Displacement Type Machines do not develop pressures on their own but work on System backpressures. Overpressure is caused by some kind of restriction on the discharge side of the blower. This is usually the result of a valve closure or line blockage caused by product build up. Likewise, discharge piping that is too small can also create an overpressure condition.

The same visible damage can be caused in a vacuum application. When compression ratios are too great, rapid heat expansion results in metal-to-metal contact. The causes are the same, blockages on the inlet or discharge side, or in some cases a combination of the two. An oversized unit can be the cause of this type of damage because of too low of a speed. The **TABLE** below gives the recommended line size based on flow and velocity.

Column I indicates the expected pressure loss, in psi, for 100 ft. of line length.

Recommended Line Size									
Drop per 100ft (30Mt)	mmWG	Max. Flow Rate		Line Size		Velocity		Min Line restriction	
		CFM	M3/hr	Inch	MM	ft/min	m/sec		
0.25	54	10	17	1.0	25	1833	9.3	14	
0.25	54	30	51	1.5	40	2444	12.4	24	
0.25	54	55	93	2.0	50	2520	12.8	33	
0.25	54	90	153	2.5	65	2639	13.4	42	
0.25	54	180	305	3.0	80	3665	18.7	60	
0.25	54	350	593	4.0	100	4009	20.4	83	
0.25	54	550	932	5.0	125	4032	20.5	104	
0.25	54	850	1441	6.0	150	4327	22.0	129	
0.20	43	1750	2966	8.0	200	5011	25.5	186	
0.15	32	2700	4576	10.0	250	4948	25.2	231	
0.13	28	3900	6610	12.0	300	4964	25.3	277	
0.12	26	5300	8983	14.0	350	4956	25.2	323	
0.11	24	7000	11864	16.0	400	5011	25.5	371	
0.09	19	8840	14983	18.0	450	5000	25.5	417	

For bends 90Deg add equivalent pipe length of 2.5*d Ft
 example: for d=3" Equivalent length to be added is 7.5 Ft.
 Based on line friction losses of 0.25 psi (170mmWg / 0.17Kg/cm2) per 100 Ft (30Mt) of pipe
 OR velocity Max 5000 Ft/min (25mt/sec) whichever lower with insertion velocity of 30mt/sec



For Bends, valves etc equivalent pipe length can be determined for loss estimations. However, care must be taken to include bare minimum restrictions, valves, bends, and change in cross-section in the discharge line since all add to the line losses effecting load on blower & the power consumed.

All types of over pressures would result in Overheating & Overloading of the Blower. Frequent Motor Tripping / Burnouts can result. Continued Overpressure can cause premature failure of Blower Internals.

STARVED INLET

The outstanding characteristic of this failure is that the rotors, face of the end plates and the inside of the housing will take on a gold discoloration. The non-drive ends of the rotors usually make contact with the end plate. The rotor tips do not normally rub but can in some cases. Damage from this condition usually isn't as extensive as overpressure because the condition uses up available horsepower and kicks out the motor.

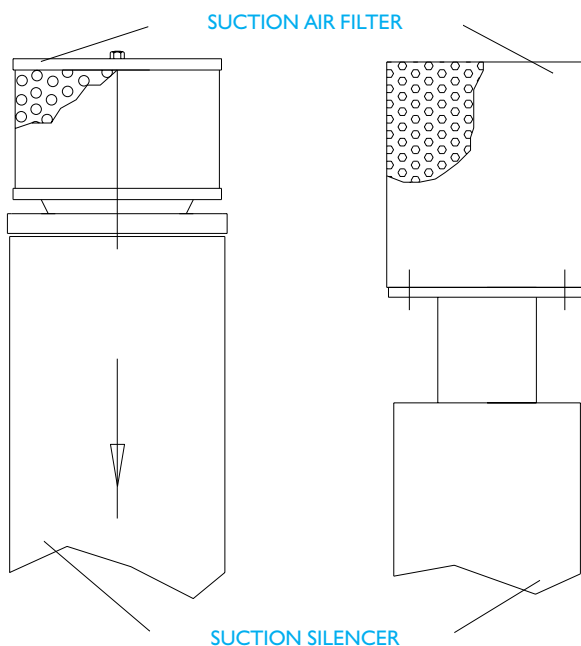

Clean Air Filter every fortnight by reverse air flow. Choked filter would result in excessive power consumption and overheating of the blower. Replace filter every three months or earlier, if inspection so demands. Check and clean Air Silencer every month.

CAUSES

A large part of the blower cooling comes from the air it draws in. When the inlet flow is restricted due to choked filter, as line blockage by a valve closure or material buildup, over heating /over loading damage occurs. **Clean/Replace filters periodically.**

A second cause is a reduction in blower speed. This could be a bad motor, loss of power, or possible single phasing of the motor. Mistakenly reversing sheaves when installing can result in this type of failure.

INSTALLATION

Areas of concern at installation are soft foot conditions, alignment of pipe loads, and drive alignment.

SOFT FOOT

These conditions result when the unit is anchored down and the surface is not flat. This condition causes a stress load at some point in the unit. When anchoring the unit down any contact point between the feet and the mounting must be shimmed to be sure the blower feet are square with the base. Do not tighten bolts to solve a soft foot condition without shimming.

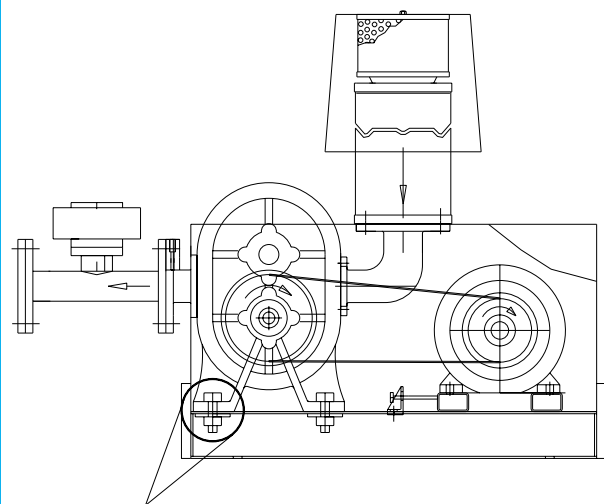

SOFT FOOT: When anchoring a unit down, any contact point between the feet and the mounting must be shimmed to be sure the blower feet are square with the base. Do not tighten the bolts to solve a soft foot condition without shimming.



EVEREST

ALIGNMENT OF PIPING

This is as critical as anchoring alignment. This is true even when a flexible connector is being used. Flanges must be aligned to avoid stress loads by trying to draw the flanges together or by forcing alignment by use of bolt or pry bar. Both the soft foot and improper piping alignment can result in premature failure of a blower. Damage from these conditions can happen at startup, or later during operation depending upon the severity of misalignment. Damage resulting from a soft foot or piping misalignment could be a bearing failure with no damage to other bearing or gears. Intermittent or random contact of rotor to endplates and/or rotor tips to housing may occur.

DRIVE ALIGNMENT AND TENSIONING

This can result in premature failure. Either belt drives or direct drives when not properly installed can result in excessive vibration and premature bearing failure. Drive alignment

damage is usually failure of the drive shaft bearing and secondary damage to the drive shaft, gears and rotors. Sheaves that are not in line with one another will over load the bearing causing it to fail. If caught early, secondary damage may not be significant. An overhung load will cause the same damage. Excessive belt tension will also result in damage to the drive shaft bearing and in many cases causes fretting corrosion along the drive line. This can occur between the drive shaft and sheave bushing, but also look for fretting corrosion between the gear and rotor shaft, between the gear hub and the inner race of the bearing or between the bearing and the rotor shaft. Damage from a direct drive misalignment usually results in a drive shaft bearing failure without secondary damage. The exception is when there is no room for expansion between the mating hubs. Bearing, gear and rotor damage can happen depending on how long the unit operates with the coupling in an axial loaded condition.

AN EASY WAY TO CHECK SHEAVE ALIGNMENT IS WITH A STRING

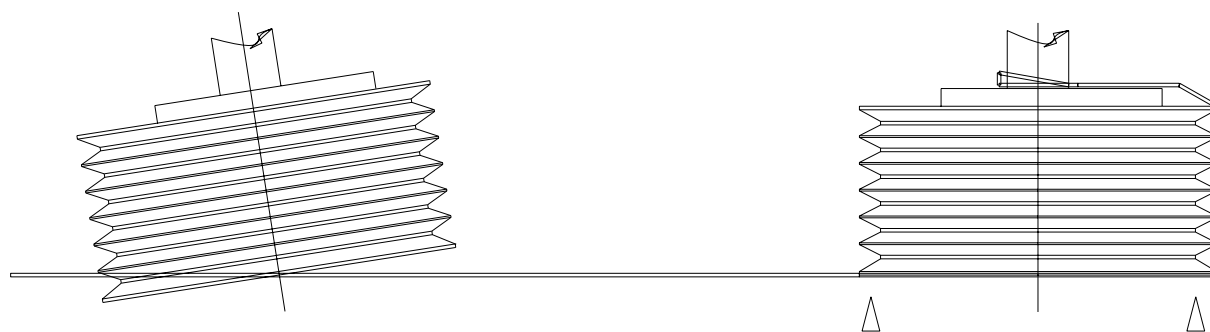

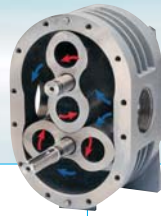

LUBRICATION

Lubrication failure is probably the most common. Most oils have lubrication additives that protect gears and bearing. Heat and contamination break down the oil, which accelerates at temperatures above 90°C. Breakdown of lubricants will vary with type of oil being used and the type of severity of service. Recommended oil changes vary from 250-1000 hours.

The BEST way to determine when to change oil is to have the oil analyzed at set periods. When tests show at what point the oil starts breaking down that is the interval at which to schedule oil changes. There are two types of lubrication damage to look for which are breakdown and lack of oil.

Ensure oil level is maintained and grease fill proper.

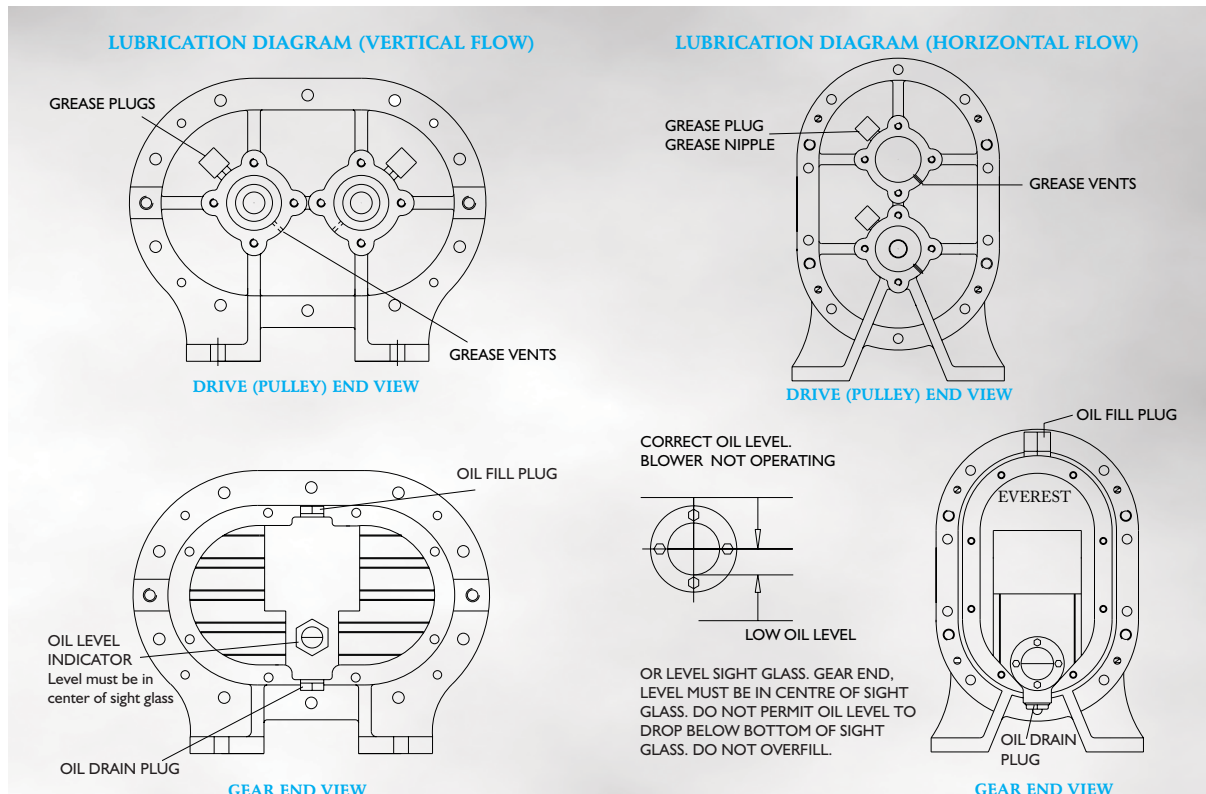



EVEREST

BREAKDOWN

The breakdown of the oil will reveal a blower with all the bearing and the gears showing some stage of deterioration. Bearings will have loose inner races and wear marks. Pitting can also occur on the balls, rollers, and races. Gear teeth will have started pitting and may be creased. Gear creasing is an advanced stage of pitting. These will be a visible wear line across the tooth down in the root. These parts may be discolored with a brown varnished color. Lip seals in many cases will be brittle or worn. Bearings can be, but are not usually burnt or melted. **Bad oil can look dirty, be thick like tar, have a strong odor, feel very gritty, or appear to be very thin in consistency.**

LACK OF OIL

Lack of oil results in catastrophic failure of bearing and gears. Gears can burn up and melt while bearings will appear to be OK. The gears can be at some stage of burning while one or more of the bearings will also burn. Usually one end of the unit will be alright

while the other end is damaged. The key to determine this type of failure is the gears. If the teeth are melted and have turned blue there was NO oil in the chamber. If the teeth are melted and the gears show shades of brown and tan, there may have been some oil but not enough to properly lubricate.

(CAUTION) Once a unit has been operated without oil-the damage is done, and deterioration will continue at a rapid rate. **DO NOT** be fooled when you see the melted gears and/or bearing and the cover is full of oil. **Regardless of the amount of and condition of the oil in the cover, it was run without oil and oil was added after the damage occurred.**

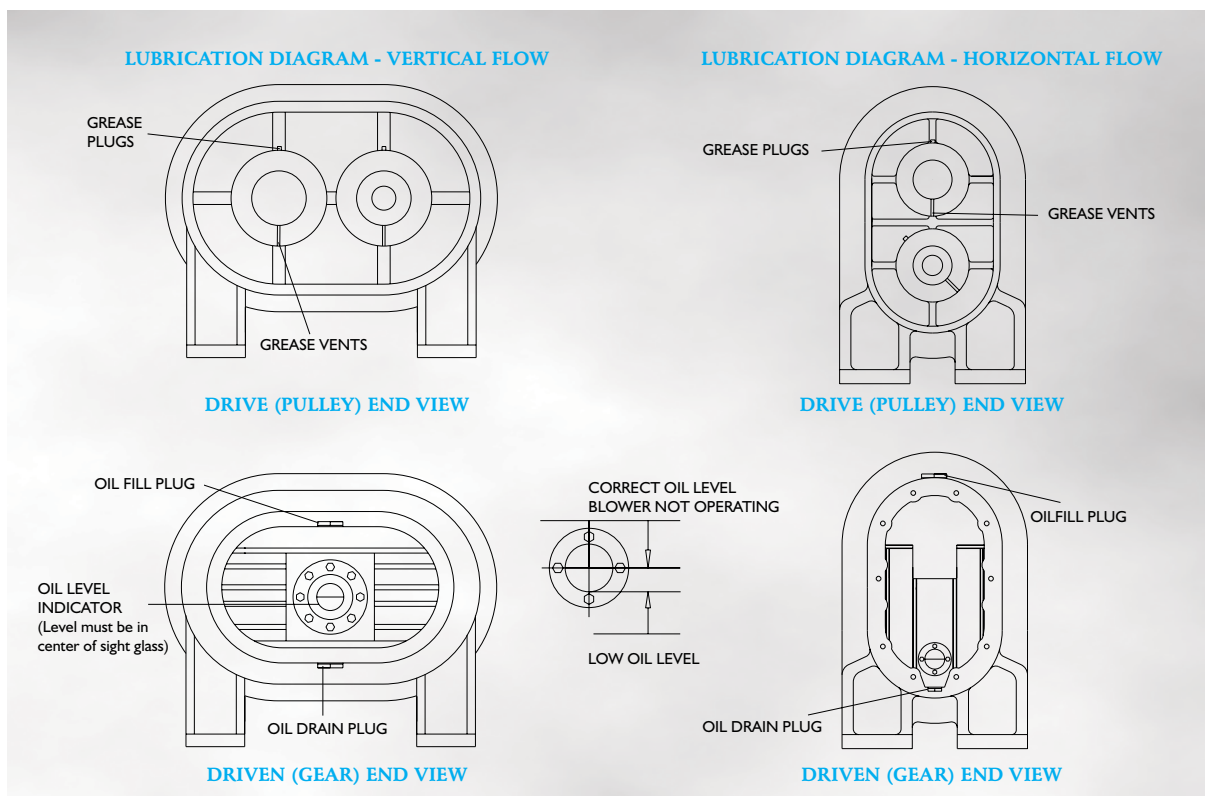



NOISE

Mechanical noise, which is caused by the blower, can be from rotor to rotor contact, which can be seen by inspecting the rotors. A bearing or gear failing or any other metal-to-metal contact will require disassembly and inspection. External sounds may appear to be coming from the blower. Loose parts or bolts on the piping as well as loose or rattling valves will make noises that appear to be coming from the blower. A blower does not change the way it sounds while running. If the sound changes during a run it is caused by some change in the operating system or its speed.

For a normal Blower the Mechanical noise is Low in comparison to the Air Borne noise. Suction of air from atmosphere and its discharge to the discharge line causes Noise Generation. Proper silencers at inlet and discharge reduce this noise considerably. However, for further reduction Acoustic Hoods are recommended. Sounds that appear to be coming from a blower may, or may not be, caused within the unit.

EVEREST EXPANDS PRODUCT LINE WITH BLOWER ENCLOSURES

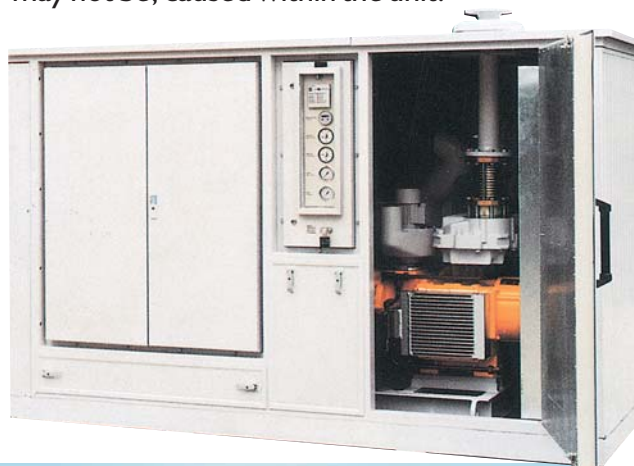

Computer Engineered Environmental products for A QUIET Environment

NON-COMPRESSIBLES

Blowers are made to move air and gases. The clearance in all units is not large enough to allow solids, slugs of liquids, or paste like materials to pass through them.

SOLIDS

Solids leave unmistakable damage. Nuts, bolts, weld slag, etc., may pass through the unit but will leave marks on the rotors and sometimes on the housing. Damage can be broken teeth on gears, rotor shafts broken, and sometimes cracked bearing bores.

Regardless of obvious damage if the rotor shafts are not broken and/or keyways spread, the rotor shafts **MUST** be checked for run out. Odds are, they are bent. Other solids such as shop rags, cigarette filters, wrappers, will not leave a mark on the rotors but the damage can be the same. Powder, paste, or flake materials may leave no visible marks, but some of the material will usually remain in the blower.

LIQUIDS

Liquids in lesser quantities can pass through a blower without damage. Slugs of liquid will cause damage that will appear as a cracked or broken housing, cracked or broken bearing bores in the endplates, broken bearing races, and possible broken rotor shafts. All, or some of this damage will be present.

SEAL LEAKS

The cause of seal leaks is best left to factory personnel or qualified repair centers. The signs of interior seal leakage are easy to diagnose. If oil is appearing in the process stream, or anywhere in the rotor housing the seals are leaking. On lip seal machines the endplates have open vent holes. If there is any oil coming from these vent holes the interior seals are leaking. There are many reasons for seals to leak.



Listed here are the more common leaks:

- Brittle or cracked sealing lip. Failure is usually caused by heat.
- Worn sealing lip. This is usually caused by a build up of dust behind the seal, which will work its way under the lip. This is usually the result of excessive material going through the blower.

Pitting, scratches, or rust on the rotor shoulder will cause a lip seal to leak. The seal journal of the rotor must be polished.

VIBRATION ANALYSIS

A machine is said to be in a state of vibrations if any of its components experiences displacement in any direction. Vibration analysis can be a good tool if the data taken from the blower is interpreted correctly. Speeds, number of lobes, or how hard the machine is working will all effect vibration readings. The best procedure is to take a baseline reading to compare future readings.

VIBRATION GUIDELINES FOR EVEREST BLOWERS

Displacement values are effective for detecting dynamic balance or alignment problems. This mode is not as sensitive in terms of detecting initial problems associated with bearings or bearing fits, or gear problems. However, displacement readings are generally not greatly affected by changes in blower speed or differential pressure, and are thus useful for cases when operating conditions can vary, or concerns of material buildup on the process exposed components of the blower exist.

Also, if a vibration meter that has only overall measuring capabilities is available, displacement values are recommended. Velocity and acceleration values are more sensitive to changes in bearing or gear condition or fit, but, however, overall values are greatly affected by changes in blower

speed or differential pressure.

If an analyzer is used that can produce readings over a broad frequency band, velocity or acceleration values can prove useful by comparing values at the frequencies and harmonics generated by the gears, bearings, and pulsations from the rotors moving the process gas. Even these values can be misleading, however, as multiple order peak values will occur over a broad frequency range, and some of these peaks can actually be a summation of the initial sources (bearings, gears, pulses, etc.), making it difficult to distinguish the condition of each individual source. For example, a bearing with 8 rolling elements will produce some vibration spikes at the same frequencies as those generated by a blower with 2 lobe rotors, as the first level frequency of the bearing will equal the multiple of 8 times the blower rpm, while the pulsation first level will equal 4 times the rpm. The result is some equivalent frequencies at the orders beyond the first level.

The following guideline for use of vibration is recommended: Regardless of the mode of measurement used, baseline values of the unit at initial use should be taken. Operating conditions should be clearly documented (rpm, inlet pressure, discharge pressure) with the baseline values. Baseline values are critical, as vibration is primarily useful for trend analysis. It is recommended to take readings in both velocity and displacement values. This allows for cross-reference and coverage of mechanical condition, alignment of drive components, and dynamic balance.

1. If velocity values increase (by a magnitude of 1 or more inches per second) but an increase in blower speed and/or differential pressure is noted, and no significant increase in displacement values occurs, it is suggested to log the data but continue operation of the equipment.



2. If velocity values increase (by a magnitude of 1 or more inches per second) with no change in blower speed and/or differential pressure, and no change in displacement values occurs, the following actions are recommended:

- Observe for any changes in noise, particularly at the bearing and gear areas, with a stethoscope.
- Check condition of the motor. If the above items have been verified and the vibration values show no improvement, contact the factory for assistance.

3. If velocity values increase (by a magnitude of 1 or more inches per second) with or without a change in bower speed and/or differential pressure, coupled with a significant increase in displacement values (1 or more mils, peak to peak), the following actions are recommended:

- Check for misalignment of the drive components.
- Check for possible buildup in the blower
- Check for material buildup in the blower.

If the above items have been verified and both vibration modes show no improvement, contact the factory for assistance.

4. If velocity values are stable, with or without a change in blower speed and/or differential pressure, coupled with a significant increase in displacement valued (1 or more mils, peak to peak) the following actions are recommended:

- Check for alignment and/or material buildup.
- Check the condition of the motor.

If the above items have been verified and the vibration values show no improvement, contact the factory for assistance.

HEATING

Inquiries about heat range from skin temperature too hot to hold hands on, oil temperatures, discharge temperature, and drive end hotter than other end.

SKIN TEMPERATURES

You cannot hold your hand on a blower when the skin temperature gets above 50°C. In general, there is no correlation between skin temperatures and operating temperatures that you need to be concerned about. Temperature largely depends on the operating pressures. Higher the pressure higher the temperature.

OIL TEMPERATURES

Oil temperatures need to be addressed when oil temperatures in excess of 80°C are reached. This usually occurs when the discharge temperature exceed 120°C. Water Cooled blowers are recommended for this range.

DRIVE/GEAR END

The gear end of a blower is hotter simply because there is a set of gears and a shaft bearing generating the heat rather than just two bearings.

DISCHARGE TEMPERATURE

The discharge temperature is a limiting factor in the operation of the blower or vacuum booster. The temperature of concern is that of the process air or gas at the discharge port. The limiting temperature will vary based upon the operating conditions of the machine. As a thumb rule discharge air temperature increases @ 10° C for every 0.1 Kg/cm² of ÄP above the inlet temperature.

NOTE: This technical document is an overview. For details on Installation, operation & maintenance please refer to the Operation & Maintenance Manual supplied along with the equipment.



TO GET THE MOST FROM YOUR EVEREST BLOWER

MAKE SURE proper oil levels are maintained in the gear end and grease in the bearing end.

CHECK OIL level and grease every 40 hours of operation. Loss of oil or grease should be replenished.

FIRST OIL change should be done within the first 100 operating hours and thereafter every 1000 hours or more often, if oil gets dirty.

CHECK BELT tension every fortnight. Too tight belts would cause premature bearing failure while too loose belts would cause overheating of belts and pulleys.

CHECK REGULARLY for any knocking or abnormal sound. high frequency sound indicates bearing trouble. Knocking sound indicates rotor timing upset. Contact "Everest" for necessary adjustments.

CLEAN AIR filter every fortnight by reverse airflow. Choked filter would result in excessive power consumption and overheating of blower. Replace filter every three months or earlier.

CHECK AND clean air silencer every month.

